

HISTORICALLY-INFLUENCED WINDOW REPLACEMENT



WAUSAU

WINDOW AND WALL
SYSTEMS

PERHAPS NO ACTION DEMONSTRATES SOCIAL RESPONSIBILITY AND ENVIRONMENTAL STEWARDSHIP MORE PROFOUNDLY THAN RESPECTFUL MODERNIZATION OF A CLASSIC ARCHITECTURAL MASTERWORK. **ART AND SCIENCE** COME TOGETHER IN THE DESIGN OF HISTORICALLY-INFLUENCED WINDOWS - WITH TODAY'S ENERGY EFFICIENCY AND EASE OF OPERATION. FOR OVER 50 YEARS, WAUSAU HAS BEEN A PART OF TEAMS OVERCOMING THESE AESTHETIC AND LOGISTICAL CHALLENGES.



FOR EDUCATION...

RUGGED HARDWARE FOR DORMITORIES - DAYLIGHTING AND VIEWS FOR ADMINISTRATIVE AND CLASSROOM BUILDINGS - FACILITY ANALYSIS AND ENERGY MODELING TO HELP "MAKE THE CASE" FOR BETTER REPLACEMENT WINDOWS

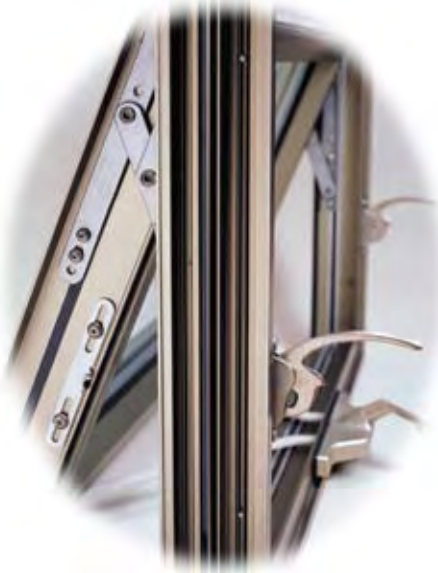

FOR HEALTH CARE...

THERMAL MODELING TO OPTIMIZE CONDENSATION RESISTANCE - EMERGENCY VENTILATION FOR PATIENT ROOMS - INDUSTRY-LEADING PSYCHIATRIC WINDOWS FOR SECLUSION ROOMS, "DROP TESTED" FOR MAXIMUM HUMAN IMPACT

VA Battle Creek Dept. of Veterans Affairs



FOR GOVERNMENT...

FULL LINE OF BLAST HAZARD MITIGATING, BALLISTIC, AND FORCED-ENTRY RESISTANT WINDOW AND CURTAINWALL PRODUCTS - CHECK OUT WWW.WAUSAUWINDOW.COM

2250-E EPIC AND 3250-H HERITAGE

SET BACK BEVELED EXTERIOR FACE TO REPLICATE PUTTY-GLAZED EXISTING WINDOW PROFILES - OPTIONAL OGEE OR RECTILINEAR PROFILED REBATES - EQUAL SIGHT LINES AT VENTS AND FIXED LITES

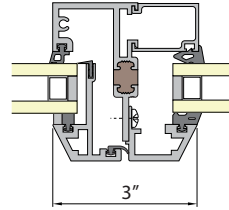

©2001 Gary Knight + Assoc. - www.garyknight.com

U.S. Courthouse Montgomery, Alabama Barganier Davis Sims

- Frame depths from 2 1/2" to 6" for small or large openings
- Polyurethane or polyamide thermal barrier
- AAMA AW-60 air, water and structural performance
- Structural "no-sag" glazing allows for large vents
- 1/8" principal wall thickness
- Uninterrupted "cruciform" reveals frame each Heritage lite



Allowable Air	Water	NFRC U-Factor	CRF _f	STC
0.10 cfm/sqft at 6.24 psf	12 psf	0.34 to 0.60 BTU/hr.sqft.°F (est)	47 to 65	33 (est)

3250-LP AND 4250-LP SIMULATED HUNG WINDOWS

PROJECTED WINDOWS WITH OFFSET GLASS PLANES TO REPLICATE EXISTING DOUBLE-HUNG SASH - BUT WITH THE EASE OF OPERATION, DURABILITY AND LOW AIR INFILTRATION OF COMPRESSION SEALS - DESIGNED ESPECIALLY FOR PUNCHED OPENINGS, OR MULTIPLE OPENINGS WITH ACCENT MULLIONS

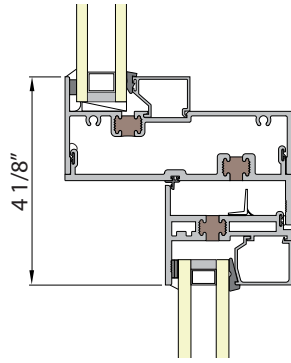

310i-SH SERIES SINGLE HUNG WINDOWS

DURABLE AW60 ARCHITECTURAL CLASS HUNG WINDOWS, WITH POLYAMIDE THERMAL BARRIER AND STANDARD CALDWELL ULTRALIFT® BALANCES

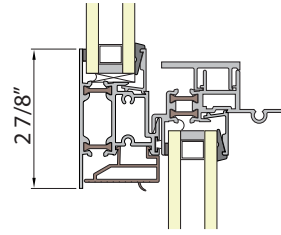

- 3½" and 4½" frame depth with polyurethane thermal barrier
- AAMA AW-60 Architectural Performance Class
- Fixed, project-out awning (4250-LP), or project-in hopper (3250-LP)
- Flush vent construction reduces collection of dust and debris
- 1/8" wall thickness at hardware connections
- Use architecturally flat 6mm glass without balance weight limits

Allowable Air	Water	NFRC U-Factor	CRF _f	STC
0.10 cfm/sqft at 6.24 psf	12 psf	0.45 to 0.61 BTU/hr.sqft. °F (est)	57 (est)	33 (est)

- Rigid "five-member" frame construction for ease of installation
- Sturdy corner-blocked and crimped sash construction
- Extruded aluminum or slide-in steel anchors
- Accepts 1" insulating glass; bead glazed
- Side load sash for cleaning

Check out www.wausauwindow.com for double hung, tilt sash and integrally-blinded options



Allowable Air	Water	NFRC U-Factor	CRF _f	STC
0.30 cfm/sqft at 6.24 psf	12 psf	0.47 to 0.65 BTU/hr.sqft. °F (est)	57	33 (est)

PANNING AND MUNTIN GRIDS

REMOVAL OF ONLY EXISTING OPERABLE SASH, LEAVING FRAMES IN PLACE, SPEEDS INSTALLATION AND MINIMIZES DISRUPTION - AN EXTRUDED ALUMINUM "PANNING" SYSTEM PREPARES THE OPENING

MUNTINS ARE AVAILABLE AS TRUE DIVIDED LITE, GLAZED-IN GRIDS, SILICONE-APPLIED, OR BETWEEN-GLASS

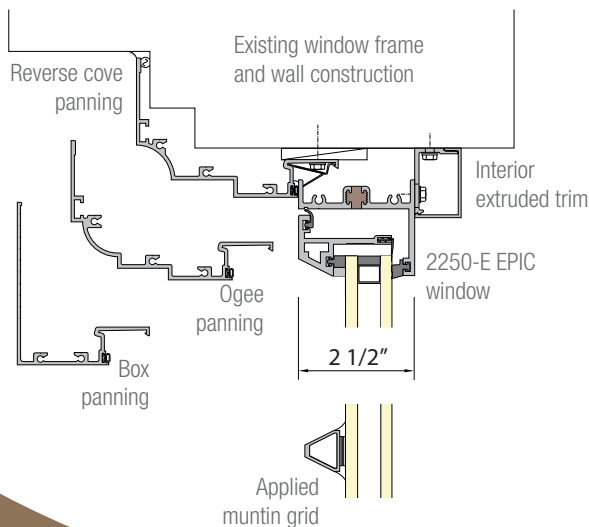

S.E.A.L. INTERIOR PRIME WINDOWS

WHEN EXISTING WINDOWS ARE WEATHER-TIGHT, AND VENTILATION IS UNNECESSARY, S.E.A.L. INTERIOR PRIME WINDOWS CAN IMPROVE SOUND, ENERGY, AIR AND LIGHT CONTROL - ECONOMICALLY, AND WITH A MINIMUM OF OCCUPANT DISRUPTION

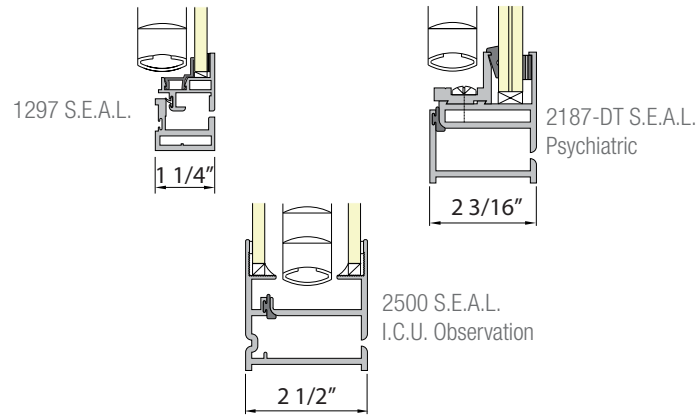

- Minimal frame depth to fit within existing window frame openings
- Also used as a curtainwall and storefront add-on for integral blinds or enhanced performance
- Side-hinged access doors with custodial locks
- 5/8" or 1" between-glass Venetian blinds available, with slip-clutch tilt control knob and concealed raise-lower controls
- Mitered frame construction, corner-blocked tubular vents
- Dual glazed 2500 Series I.C.U. observation windows
- Drop tested 2187-DT Series accepts psychiatric glazing, ideal for adaptive re-use





Wausau Manufacturing Center

Somerville Architects

THE USGBC LEED® GREEN BUILDING RATING SYSTEM IS NOT LIMITED TO NEW BUILDINGS LIKE WAUSAU'S LEED-SILVER CERTIFIED MANUFACTURING CENTER - EXISTING BUILDINGS CAN QUALIFY AS MAJOR RENOVATIONS THROUGH LEED-NC, OR THROUGH LEED-EB FOR EXISTING BUILDINGS.

HOW CAN WINDOWS CONTRIBUTE ?

- LOW U-FACTOR
- LOW SOLAR HEAT GAIN COEFFICIENT
- NATURAL VENTILATION
- DAYLIGHTING AND VIEWS
- RECYCLED ALUMINUM FRAMES

WHY ALUMINUM WINDOWS ?

- LONG-TERM DURABILITY
- WEATHER RESISTANCE
- MATERIAL STABILITY
- LARGE OPERATING VENTS
- RECYCLED CONTENT
- FACTORY-APPLIED ECO-FRIENDLY FINISHES
- NON-CONDUCTIVE THERMAL BARRIERS
- ECONOMICAL CUSTOMIZATION



BEYOND LEED®

SUSTAINABLE MANUFACTURING PROCESSES

- Minimized packaging materials in receiving and shipping
- Scrap recycling: Aluminum, steel, cardboard, wood, glass, fluorescent bulbs, paper, beverage containers, toner cartridges, electronic equipment
- "Paperless" environment supported by Wausau ShopView™ software
- 98% VOC-capture spray painting of durable AAMA 2605-tested fluoropolymer
- No-VOC finish options: Powder coatings and durable Class I anodic finishes
- Resource-wasting internal rework minimized through Lean/Six Sigma

SUSTAINABLE BUSINESS PRACTICES

- Leadership within industry trade organizations and research groups
- Design charrettes supported with engineering resources
- All operable windows are durable, cycle-tested AW-Class
- LEED-AP on staff



SPECIFICATIONS

THE UNIQUE LOGISTICAL CONSIDERATIONS OF REPLACEMENT PROJECTS CAN BE IMPACTED CONSIDERABLY BY THE EXTENT OF WORK REQUIRED, AS WELL AS THE EARLY DECISION ON EXTERIOR OR INTERIOR ACCESS



Comprehensive drawings and specifications ensure complete and competitive bids. Contract documents should include:

- A complete description of work to be performed; to include instructions on panning versus tear-out of existing frames
- Specific minimum requirements for performance, materials, fabrication, finish, operation, and hardware selection
- Pre-qualification procedures for manufacturers and installers
- Field testing and quality control expectations
- Details ensuring the integrity of the building shell is maintained - air/moisture transmission, compatible materials, and thermal expansion
- Related work such as plaster repair or molding removal/replacement
- General conditions, including bonding, insurance, and warranty
- Sequence of work and schedule
- Instructions for deliveries and disposal of materials removed, such as diverting demolition debris from landfills and the recycling of glass
- Access to, and protection of, occupied spaces and their contents
- Working hours
- Available outside and inside storage.



Samples installed in an easily accessible on-site location offer first-hand experience in field measuring, removal, and replacement logistics.

WARRANTY



FOR MORE THAN 50 YEARS, WAUSAU HAS WORKED CLOSELY WITH ARCHITECTS, BUILDING OWNERS AND CONTRACTORS TO REALIZE THEIR VISION FOR

AESTHETICS, SUSTAINABILITY AND LASTING VALUE,

WHILE STRIVING TO MAINTAIN THE HIGHEST LEVEL OF CUSTOMER SERVICE, COMMUNICATION AND OVERALL SATISFACTION



WAUSAU

WINDOW AND WALL
SYSTEMS

7800 INTERNATIONAL DRIVE P.O. BOX 1746 WAUSAU, WI 54402-1746
TOLL FREE 1 877 678 2983 FAX 1 715 843 4350
E-MAIL INFO@WAUSAUWINDOW.COM