

Curtainwall and Window Wall

SUPERWALL™ SSG FOUR-SIDE SILICONE

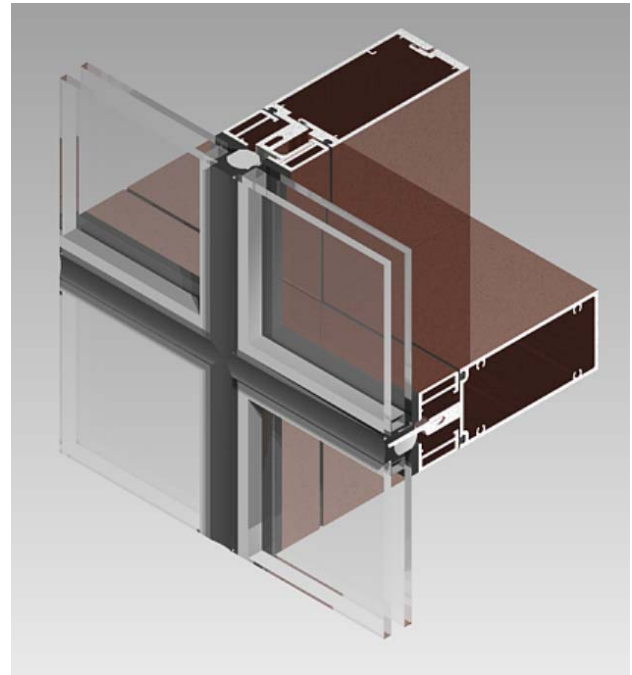
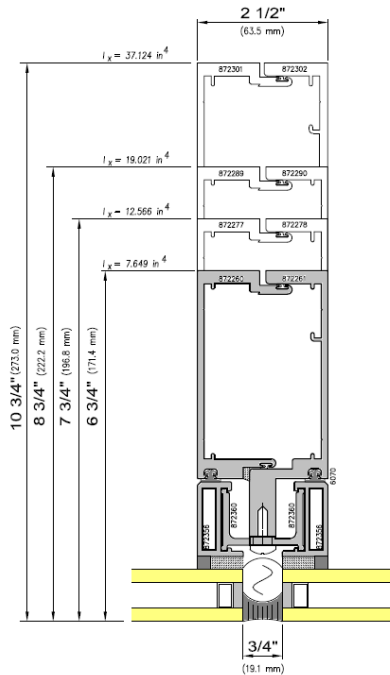

Features

- ✓ 6 ¾", 7 ¾", 8 ¾", or 10 ¾" total system depth (with standard 1" glass)
- ✓ Grid frames are factory fabricated and shipped knocked-down (KD) for field assembly
- ✓ All grid framing is interchangeable with standard Wausau SuperWall™ systems
- ✓ Carrier frames are factory four-side structural glazed in a controlled environment
- ✓ No exterior exposed framing
- ✓ Field face-sealed
- ✓ "F" and "T" perimeter anchors
- ✓ Exterior accent trim available
- ✓ Zero sightline vent inserts
- ✓ Exterior sun shades and interior light shelves available
- ✓ High recycled content extruded aluminum frames

Performance

Allowable Air
0.06 cfm/sqft at 6.24 psf
Water
15 psf
NFRC U-Factor
0.37 to 0.55 BTU/hr.sqft.°F (est)
CRF_f
70 to 74 (est)
STC
31 to 34 (est)



DISCLAIMER: Wausau Window and Wall Systems takes no responsibility for product selection or application, including, but not limited to, compliance with building codes, safety codes, laws, merchantability or fitness for a particular purpose; and further disclaims all liability for the use, in whole or in part, of this Technical Guide in preparation of project specifications and/or other documents. Technical Guides are subject to change at any time, without notice, and at Wausau's sole discretion. © 2014 Apogee Wausau Group, Inc.