



**WAUSAU**

WINDOW AND WALL  
SYSTEMS

Test Unit Elevations

Architectural Windows

4100i-HS Double Slide and Fixed Series

Elevations Viewed From The Exterior

**Section Contents**

Page(s)

Details.....	S2-2 through S2-4
Mullion Stacks.....	S2-5
Glazing Options.....	S2-6
Accessories.....	S2-7 and S2-8

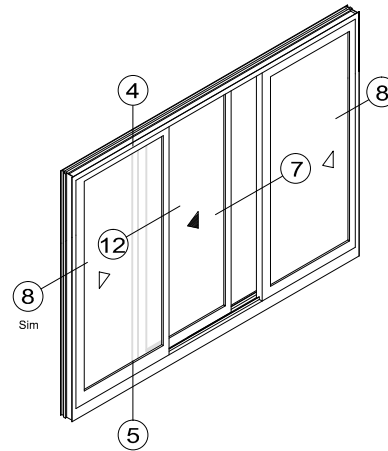

**AAMA Test Configurations** (shown)

Architectural AW Class

For air, water, cycling and structural

Fixed Frame Size	59" x 98"	Fixed	1500 mm x 2500 mm
Horizontal Slider Size	98" x 79"	Type B	2500 mm x 2000 mm

**AAMA**

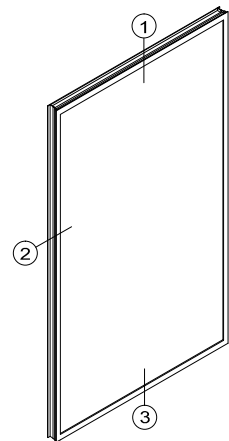

**NFRC 100 Thermal Test Configurations** (shown)

For U-Factor, SHGC and CR

Fixed Frame Size	47" x 59"	1200 mm x 1500 mm
Horizontal Slider Size	59" x 47"	1500 mm x 1200 mm

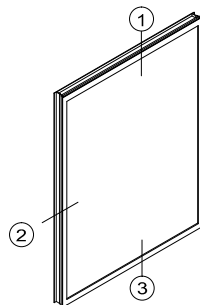

**NFRC**

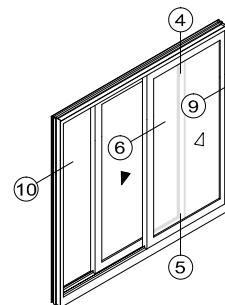

**4100i-HS**

Contact A Wausau Representative For Other Possible Configurations.



**WAUSAU**

WINDOW AND WALL  
SYSTEMS

Sliding and Fixed Details

Architectural Windows

4100i-HS Series

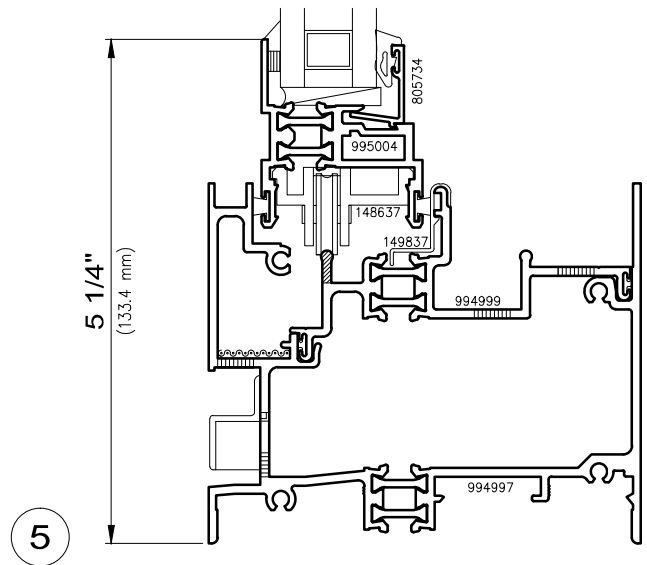
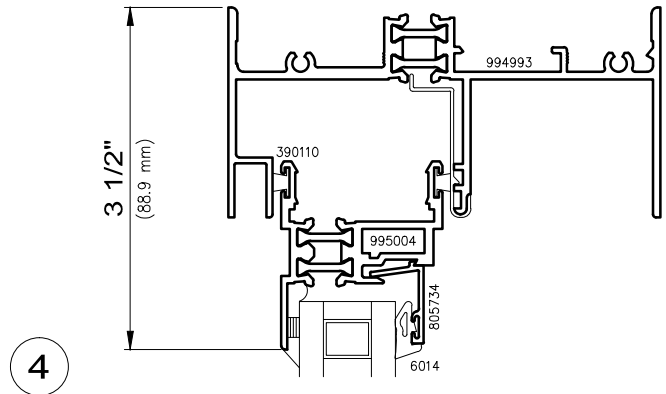
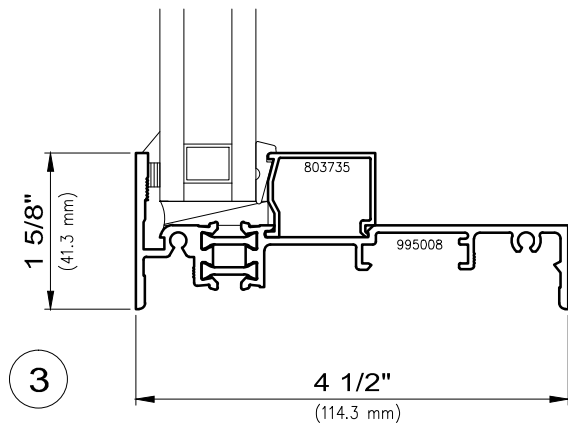
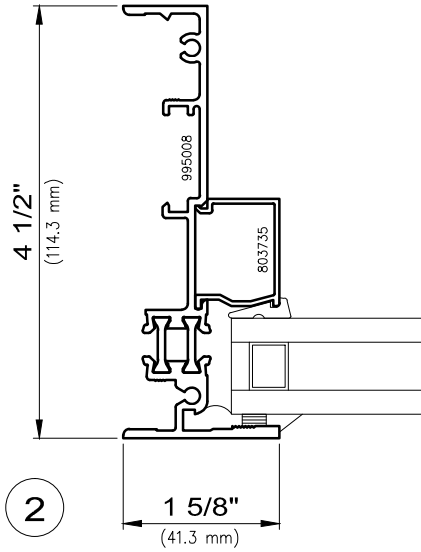
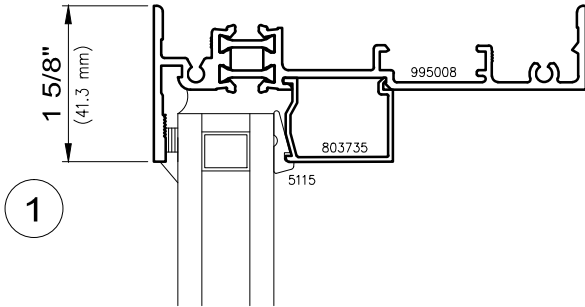

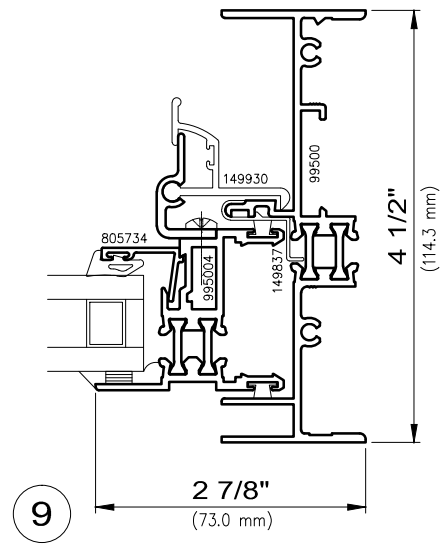
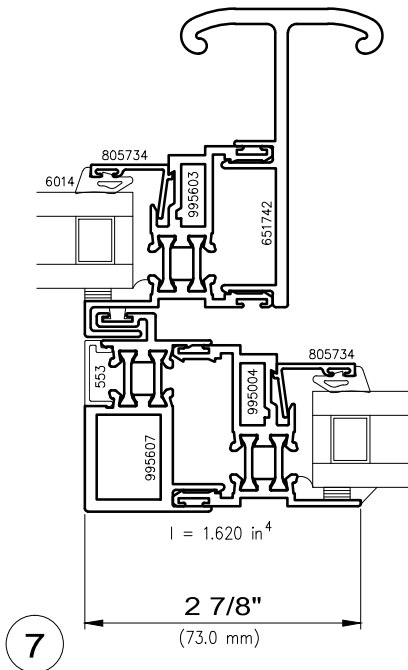
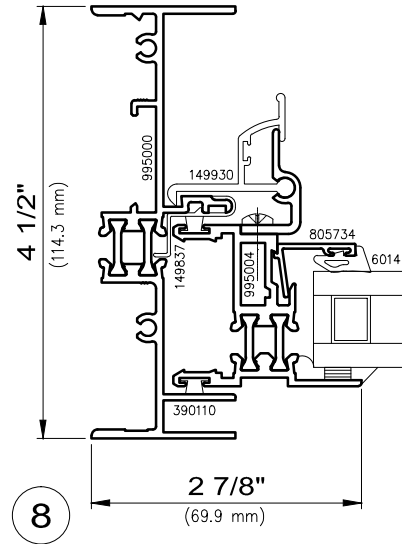
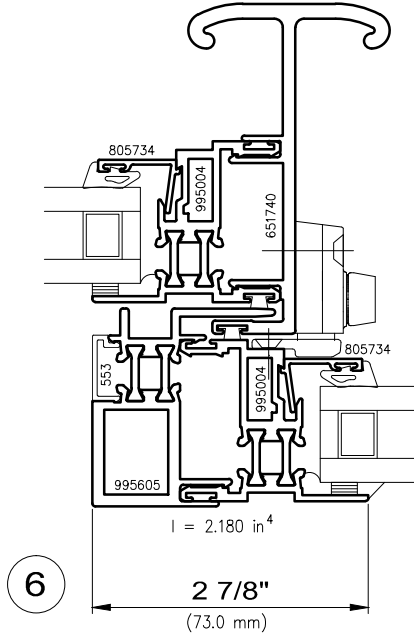

I-values indicated are for frame members only.  
Thermal barrier shear reduction of 10% included.

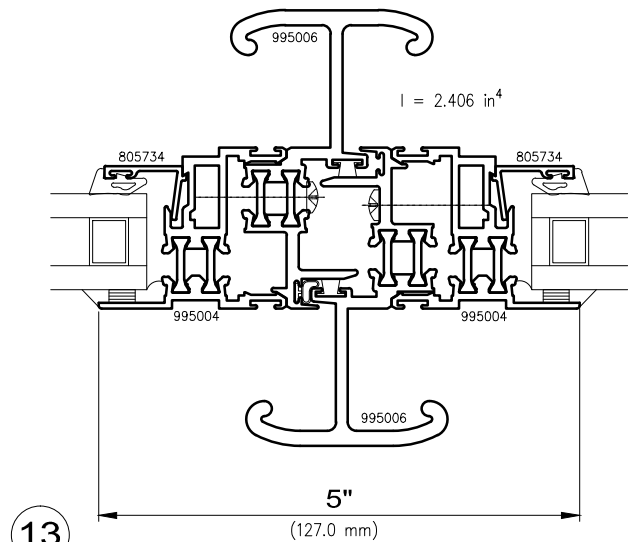
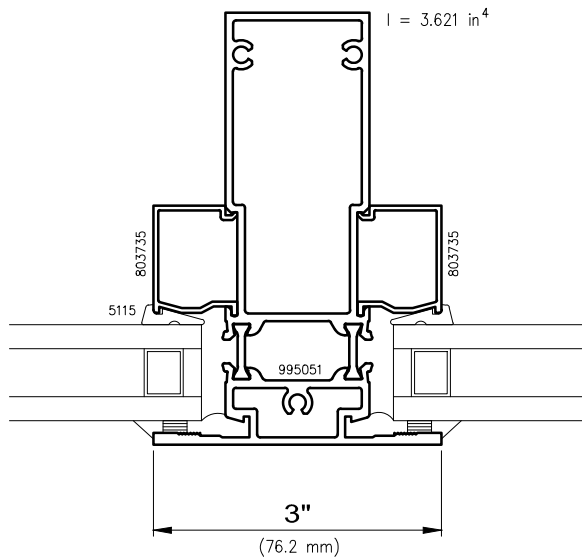
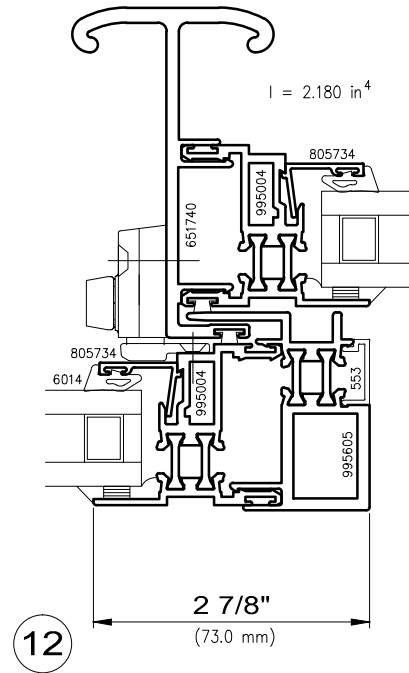
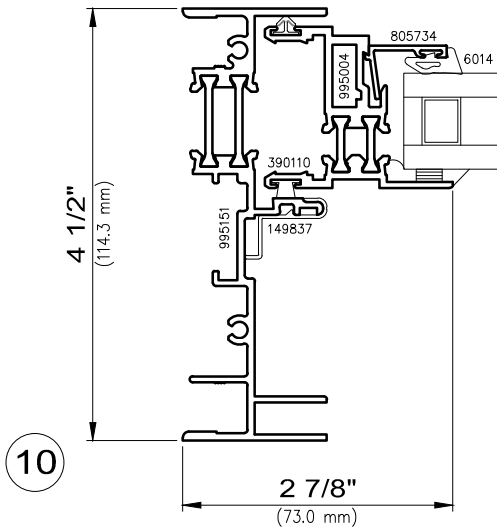

Operable/Operable  
Center Open

I-values indicated are for frame members only.  
Thermal barrier shear reduction of 10% included.

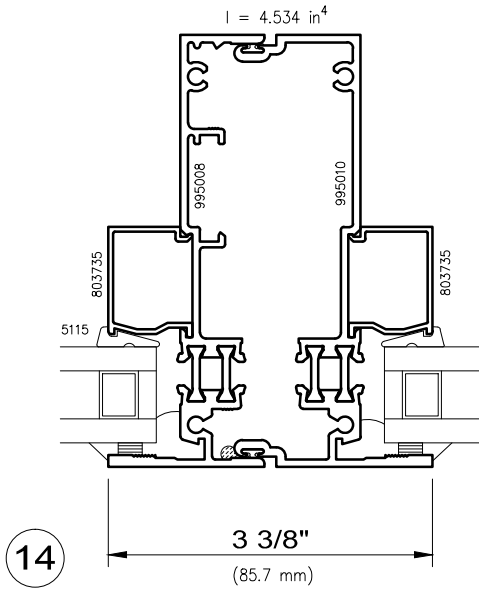

Fixed/Fixed

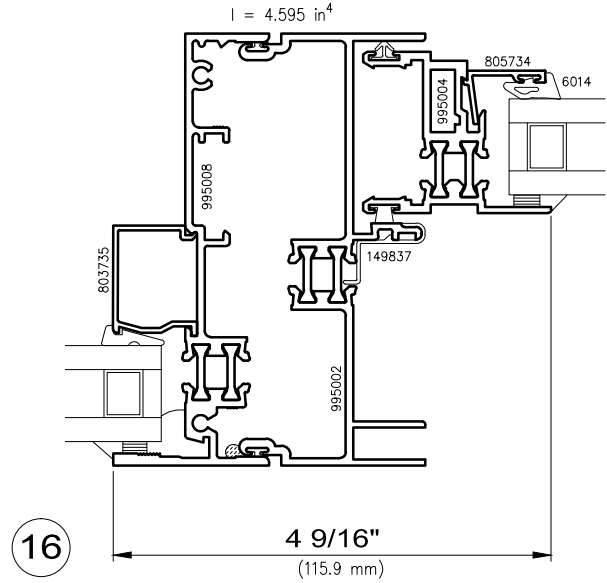

Fixed/Operable

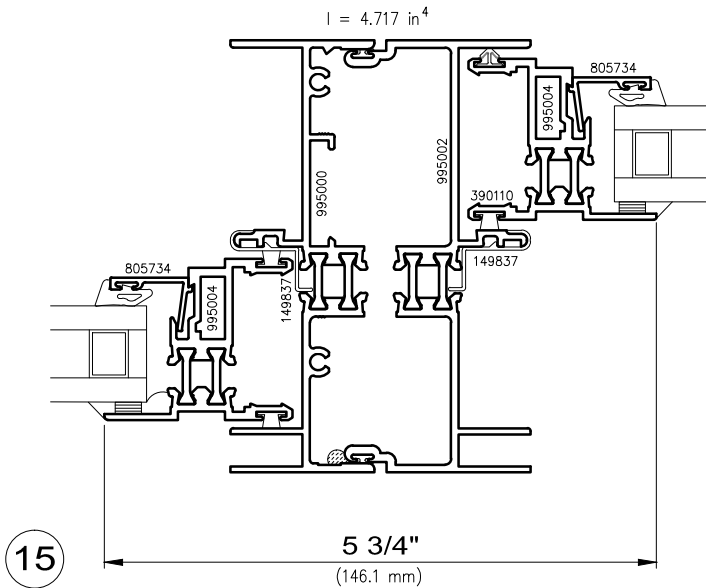

Operable/Operable

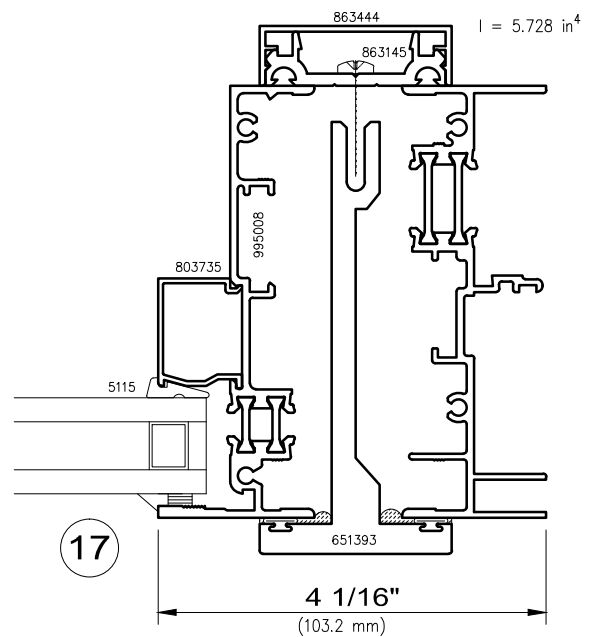

Flat Mullion

I-values indicated are for frame members only.  
Thermal barrier shear reduction of 10% included.

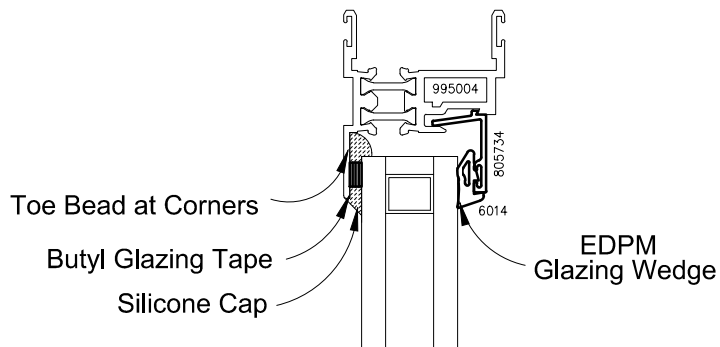

1" Insulating Glass  
Operable Inside Glazed

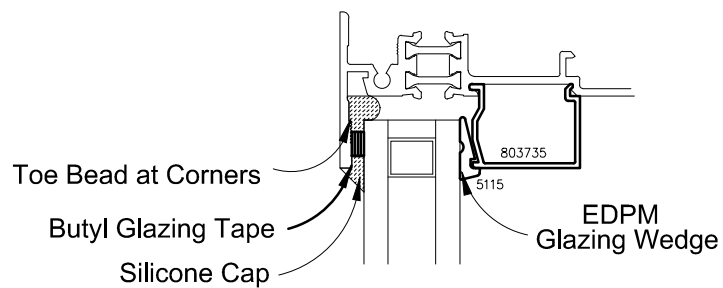

1" Insulating Glass  
Fixed Inside Glazed



**WAUSAU**

WINDOW AND WALL  
SYSTEMS

Accessories  
Head, Jamb, and Sill Starters

Architectural Windows

4100i-HS Series

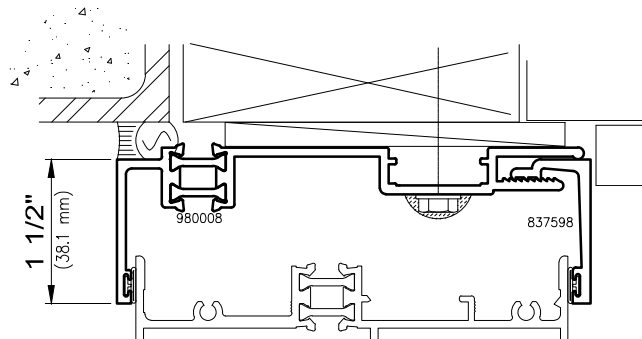

4250i Head & Jamb Starter

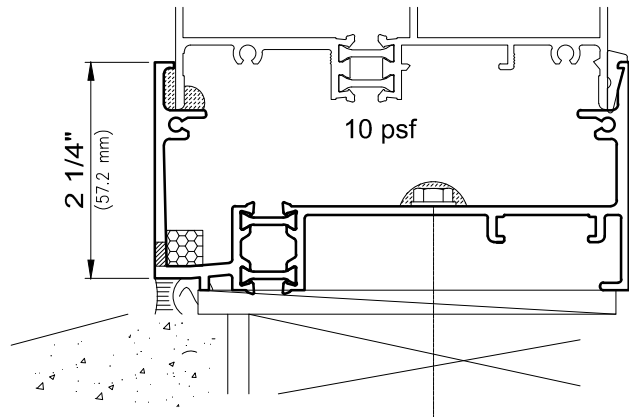

4250i Sill Starter



**WAUSAU**

WINDOW AND WALL  
SYSTEMS

Accessories  
Anchor Options

Architectural Windows

4100i-HS Series

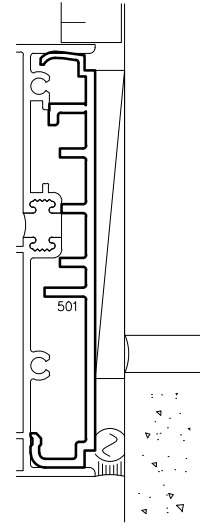
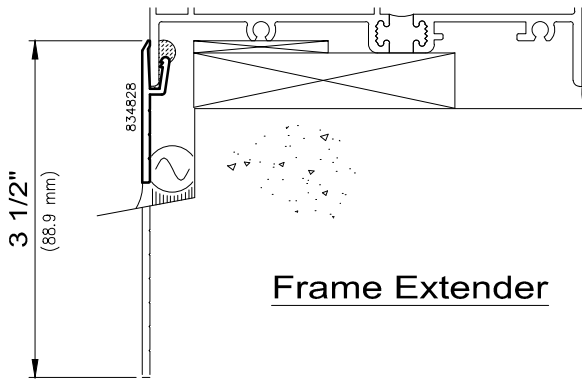

PVC Shim Block

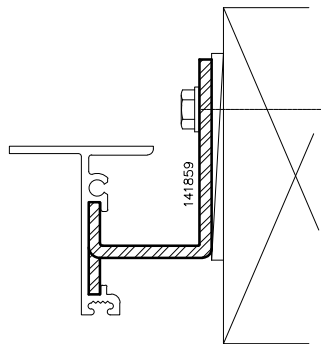

Twist-In Anchor  
1/8" Formed Steel

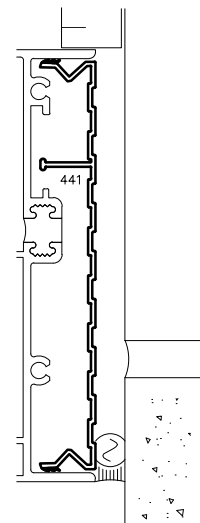

PVC Caulk Backer