

Architectural Windows

2250i/3250i/4250i INvent™ Series

Elevations Viewed From The Exterior

**Section Contents**

Details	P17-2 thru P17-4
Posts and Stacks	P17-5 thru P17-7
Glazing Options	P17-8 and P17-9
-BHM Blast Mitigation	P17-9
-HP Hurricane Impact	P17-9
Blind Options	P17-10 and P17-11
Simulated Double Hung	P17-12 thru P17-15
Accessories	P17-16 thru P17-19
Isometric Views	P17-20 and P17-21

**AAMA Test Configurations** (shown)

Architectural AW Class

For air, water, cycling and structural

Fixed Frame Size	60" x 99"	Fixed	1524 mm x 2515 mm
Projected Frame Size	60" x 144"	Type D	1524 mm x 3658 mm
Casement Frame Size	108" x 60"	Type D	2743 mm x 1524 mm
Gateway Sizes	60" x 36"	Projected	1524 mm x 914 mm
	36" x 60"	Casement	914 mm x 1524 mm

**NFRC 100 Thermal Test Configurations** (shown)

For U-Factor, SHGC and CR

Fixed Frame Size	47" x 59"	1200 mm x 1500 mm
Projected Frame Size	59" x 24"	1500 mm x 600 mm
Casement Frame Size	24" x 59"	600 mm x 1500 mm

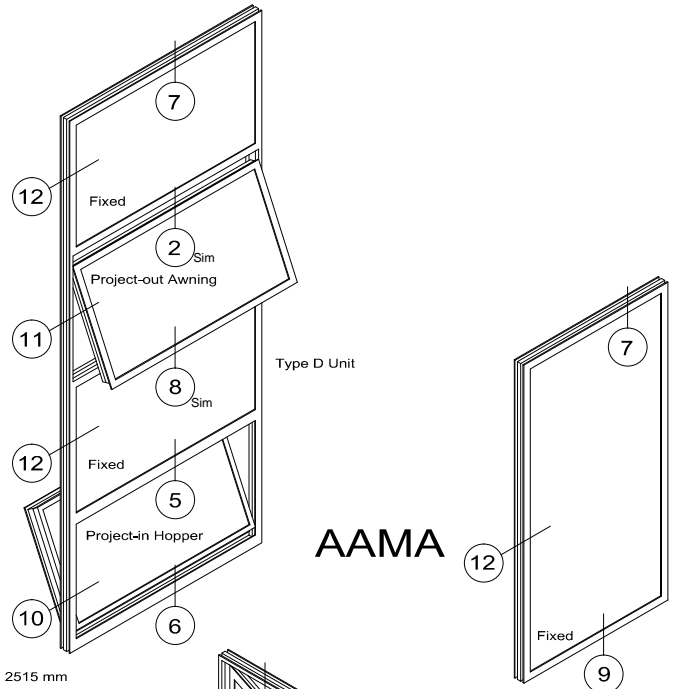

**AAMA**

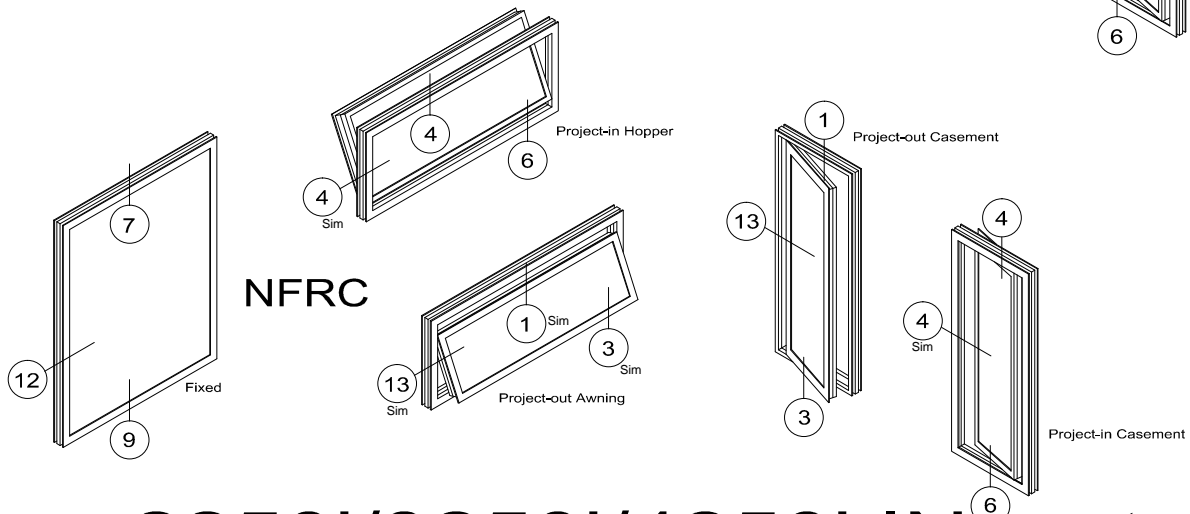
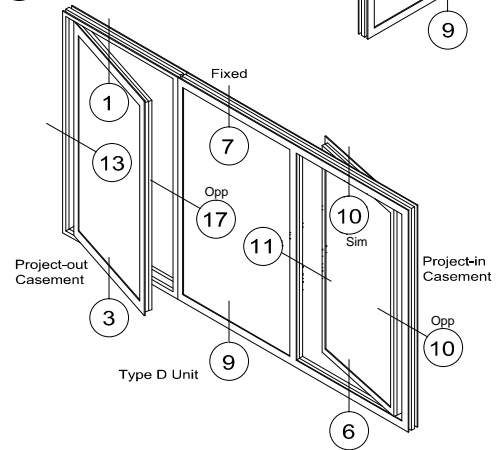

# 2250i/3250i/4250i INvent

Contact A Wausau Representative For Other Possible Configurations



## Architectural Windows

## 2250i/3250i/4250i INvent™ Series

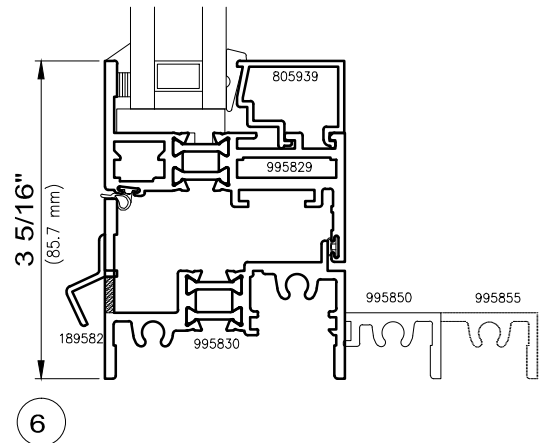
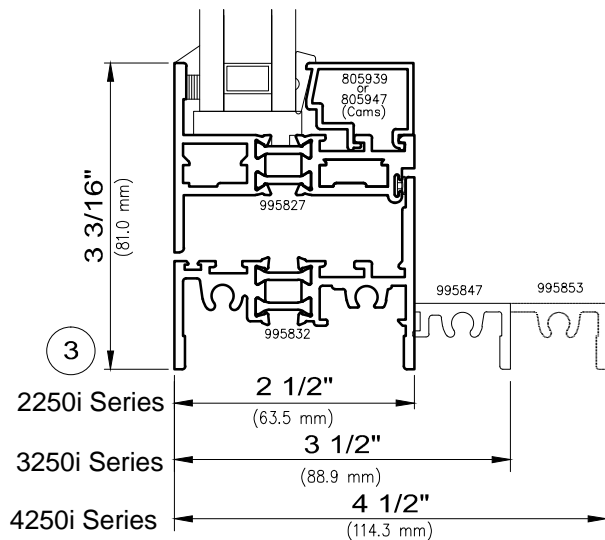
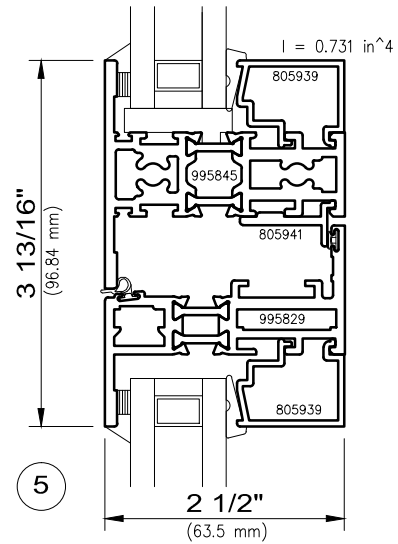
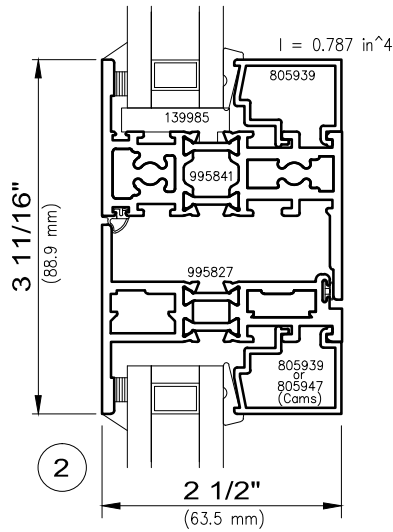
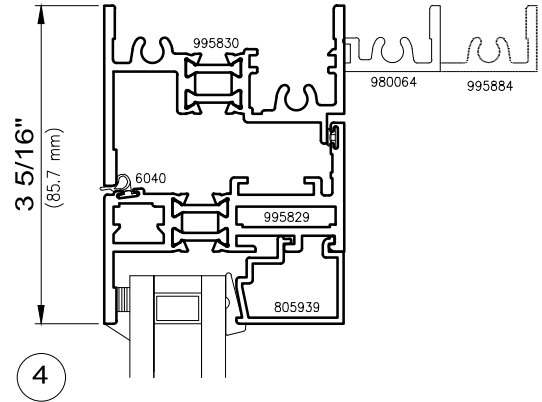
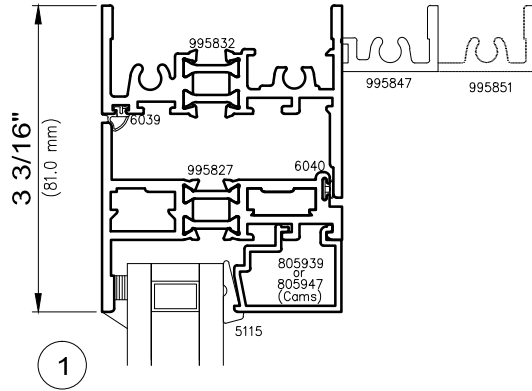



**WAUSAU**

WINDOW AND WALL  
SYSTEMS

Projected and Fixed Details

Architectural Windows

2250i/3250i/4250i INvent™ Series

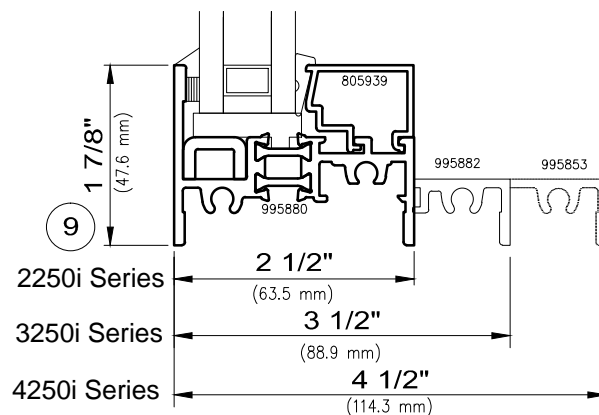
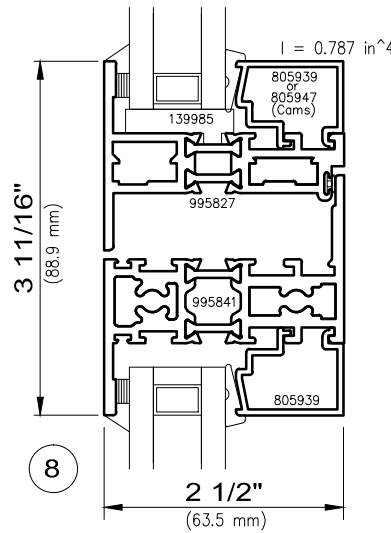
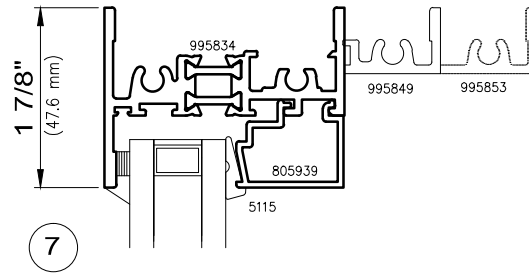



**WAUSAU**

WINDOW AND WALL  
SYSTEMS

Projected and Fixed Details

Architectural Windows

2250i/3250i/4250i INvent™ Series

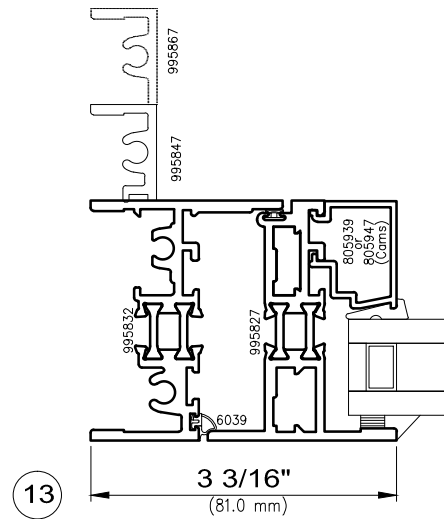
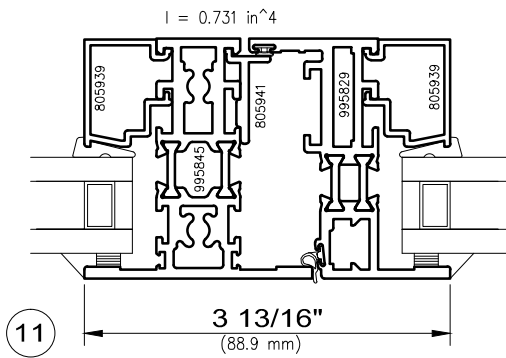
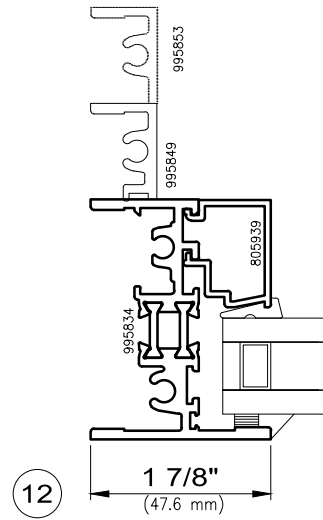
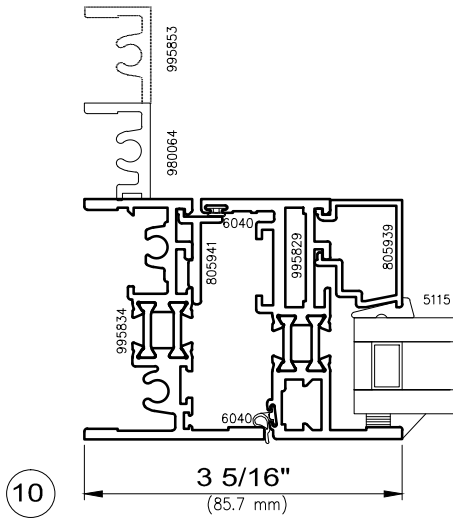

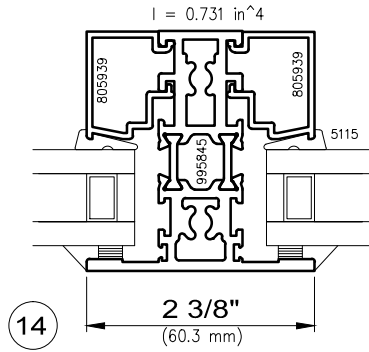

Fixed / Fixed Post

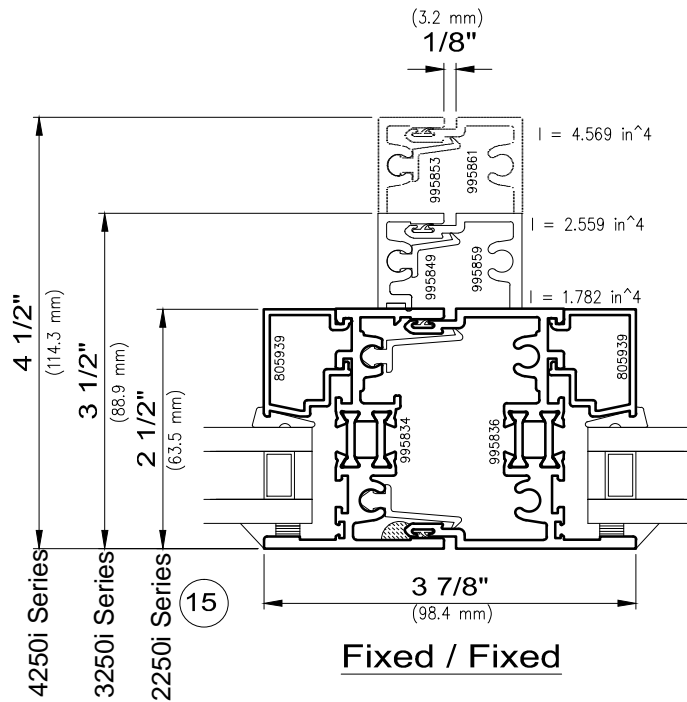

Fixed / Fixed

I-values indicated are for frame members only.  
Thermal barrier shear reduction of 10% included.

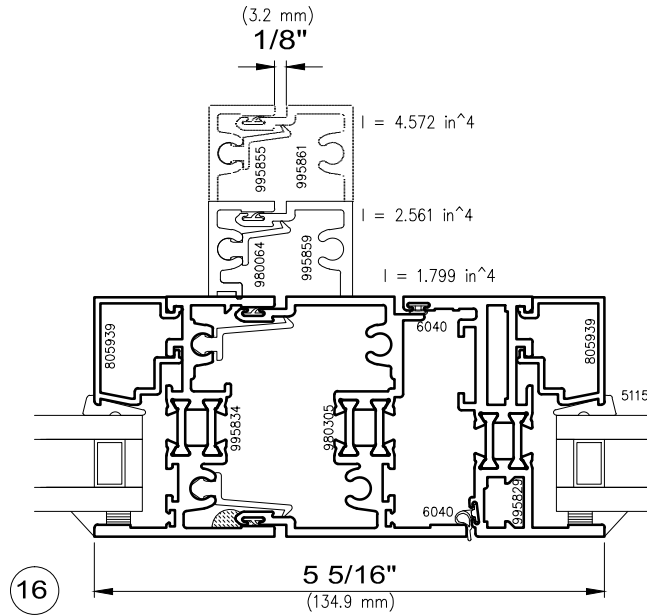

Fixed / Project-In

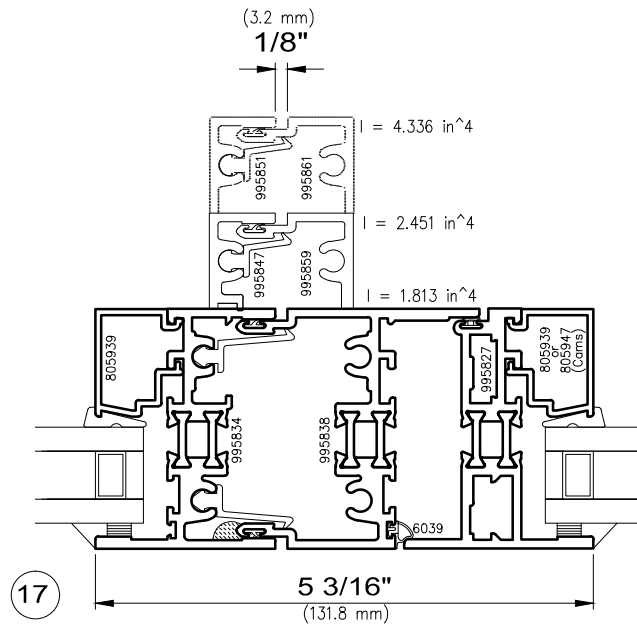

Fixed / Project-Out

I-values indicated are for frame members only.  
Thermal barrier shear reduction of 10% included.

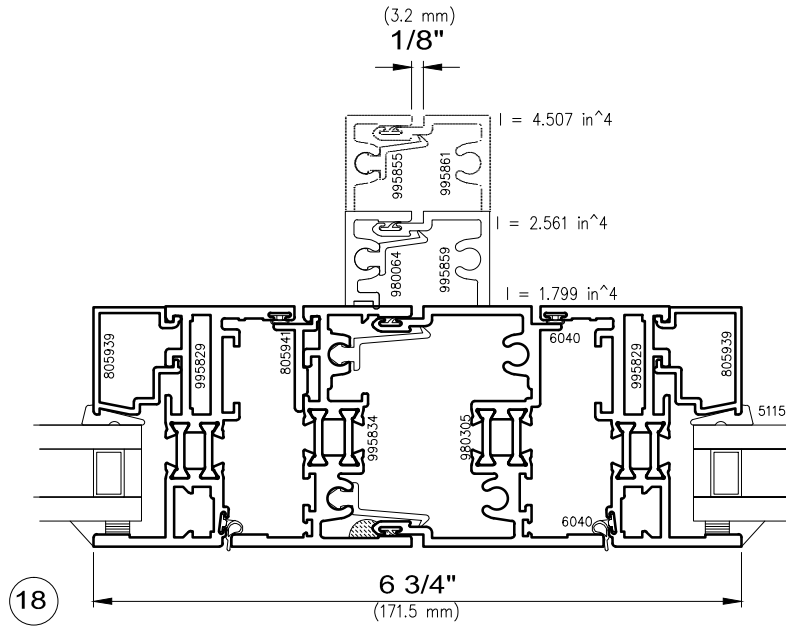

Project-In Vent / Project-In Vent

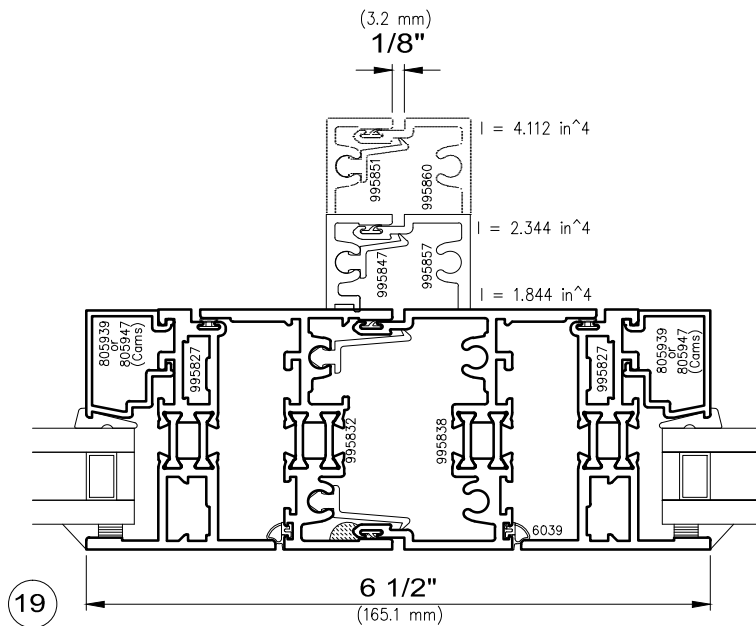

Project-Out Vent / Project-Out Vent

I-values indicated are for frame members only.  
Thermal barrier shear reduction of 10% included.



**WAUSAU**

WINDOW AND WALL  
SYSTEMS

Glazing Options

Architectural Windows

2250i/3250i/4250i INvent™ Series

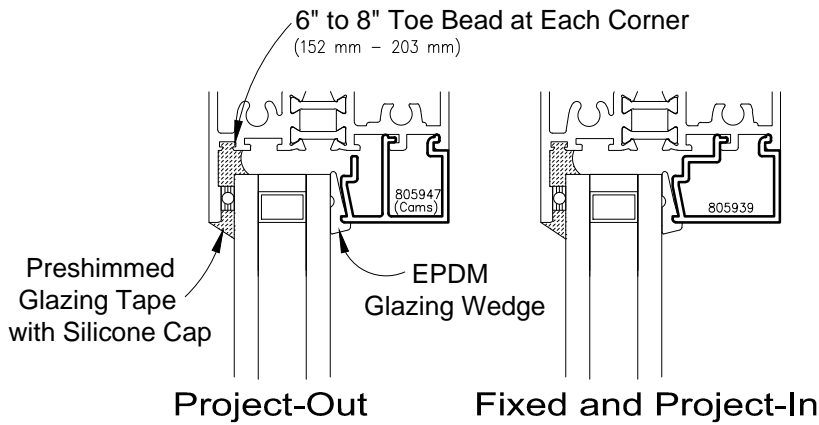

1" Insulating Glass  
Inside Glazed

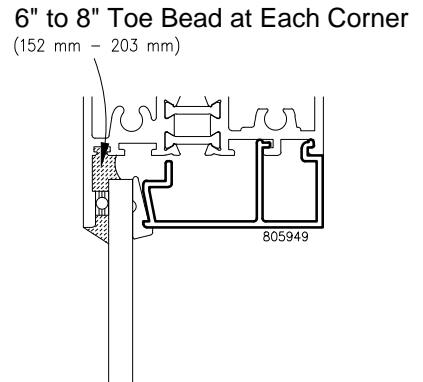

1/4" Monolithic Glass  
Inside Glazed

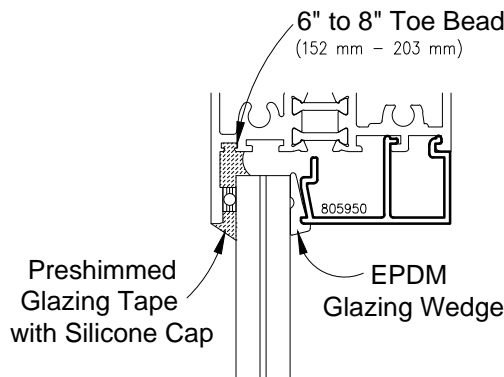

9/16" Laminated Glass  
Inside Glazed

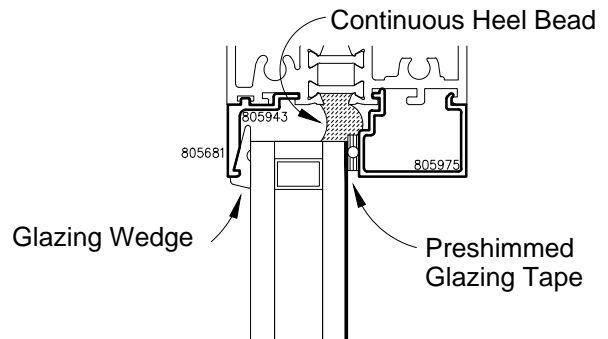

1" Spandrel  
Outside/Inside Glazed

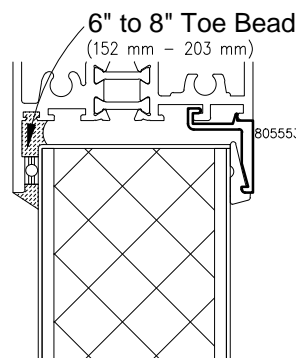

2" Panel  
Inside Glazed



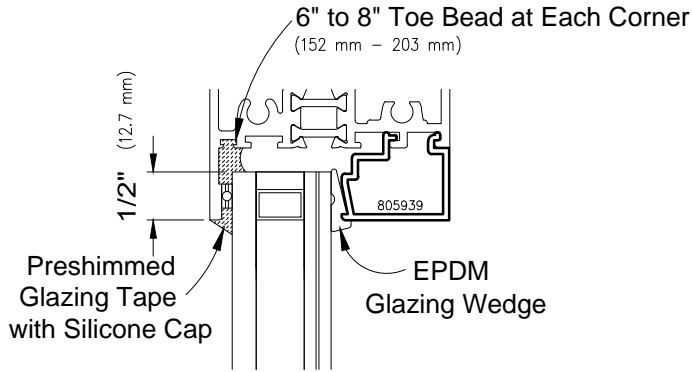

1 1/16" (nom.) Insulating Laminated Glass  
Inside Glazed

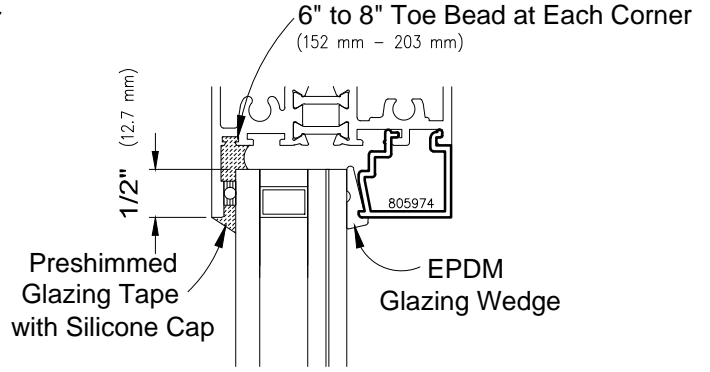

1 3/16" (nom.) Insulating Laminated Glass  
Inside Glazed

**-BHM Blast Hazard Mitigation**

Peak Pressure and Impulse up to 10 psi - 89 psi-msec  
Not available in Simulated Double Hung

Contact Wausau for  
blast glazing details  
applicable to the  
specific requirements  
of your project

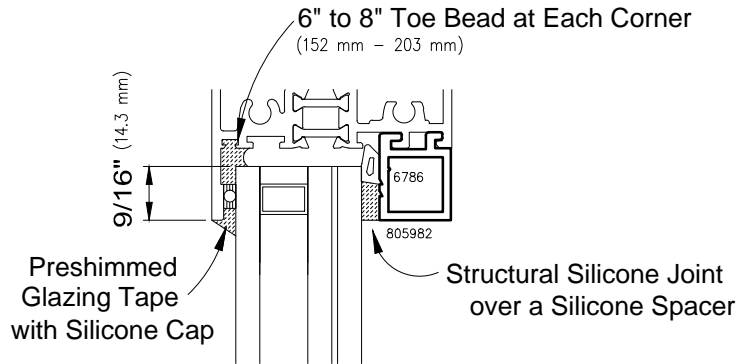

1 5/16" (nom.) Insulating Laminated Glass  
Inside Glazed

Architectural Windows

2250i/3250i/4250i INvent™ Series

Elevations Shown As Viewed From The Interior

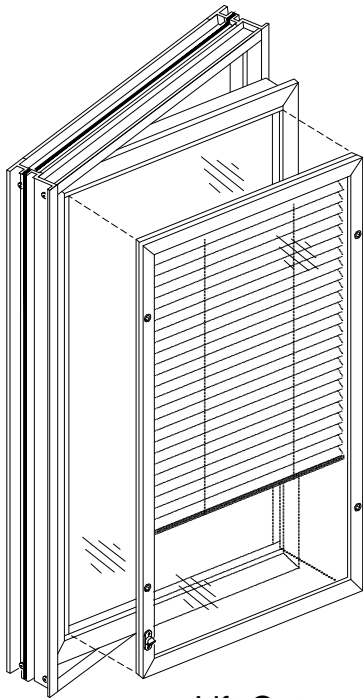

Lift-Out

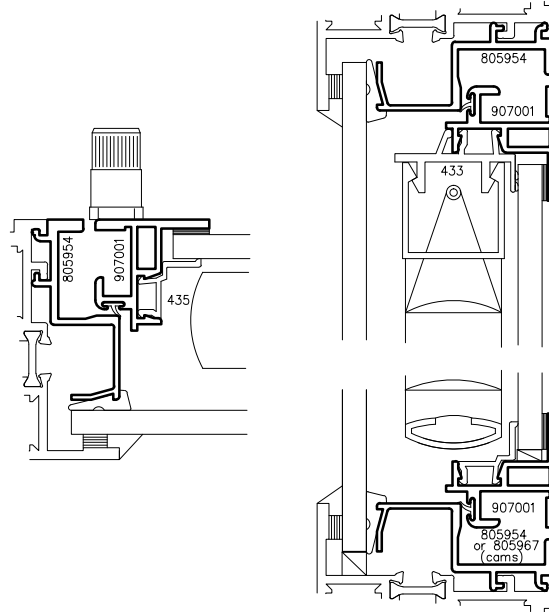

1" Blind/Dual Glazed

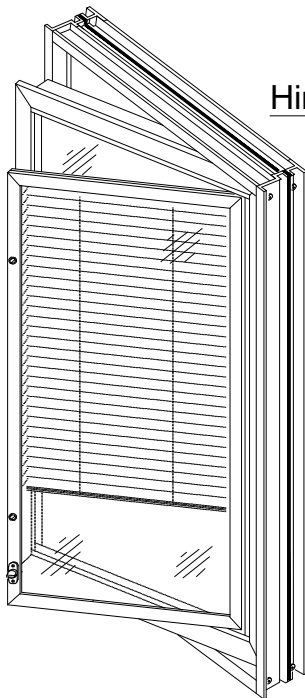

Hinged

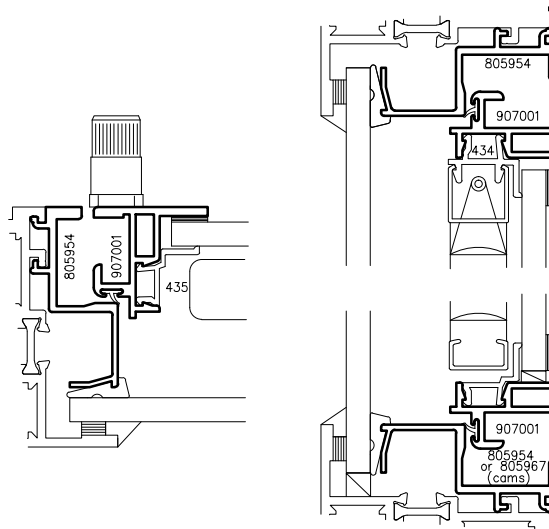

5/8" Blind/Dual Glazed



**WAUSAU**

WINDOW AND WALL  
SYSTEMS

Blind Options

Architectural Windows

2250i/3250i/4250i INvent™ Series

Elevations Shown As Viewed From The Interior

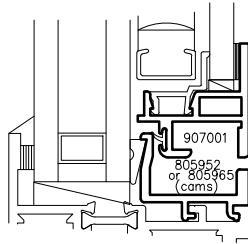
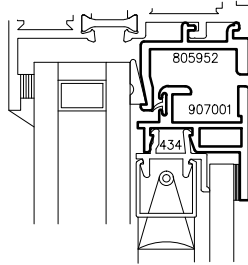
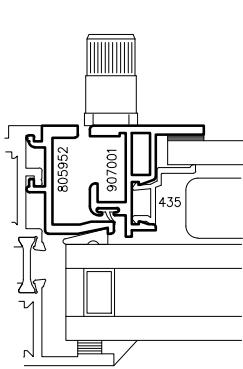

5/8" Blind/Triple Glazed

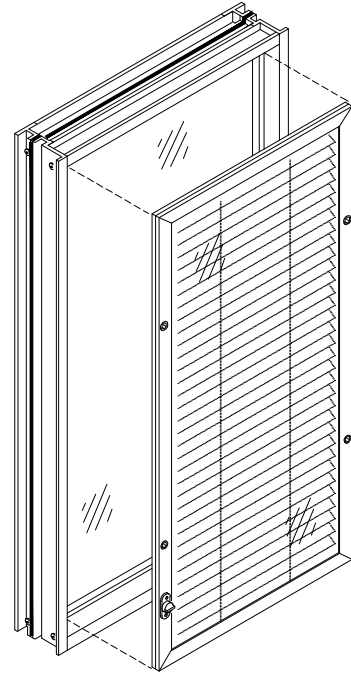

Lift-Out

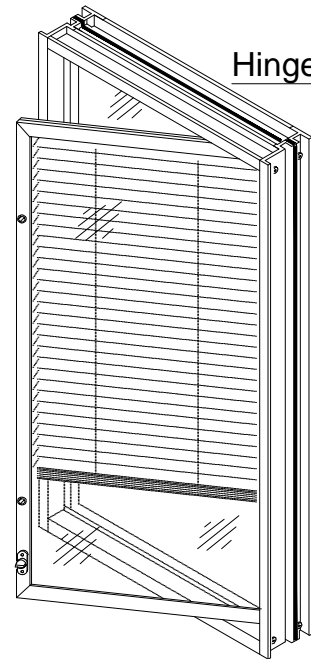

Hinged



**WAUSAU**

WINDOW AND WALL  
SYSTEMS

Simulated Double Hung  
Panning and T-Mullions

Architectural Windows

2250i/3250i/4250i INvent™ Series

Non-stocked items shown - Minimum order quantity may apply

Panning and mullions are available in various depths, with optional historic ogee or reverse cove profiles. Refer to "Accessories" for more information.

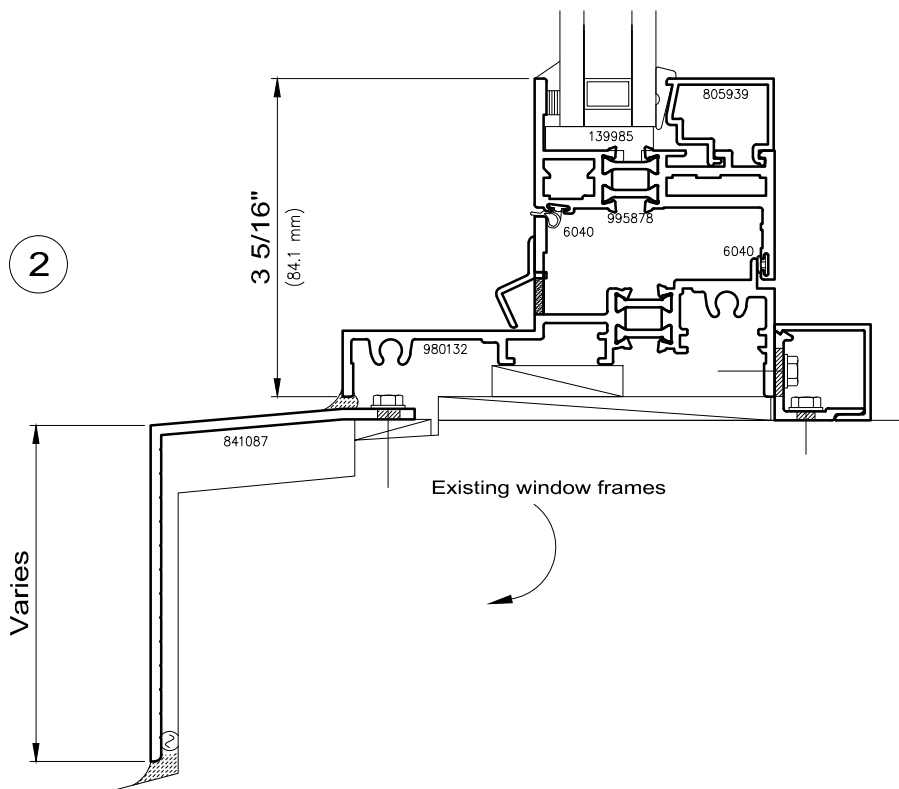
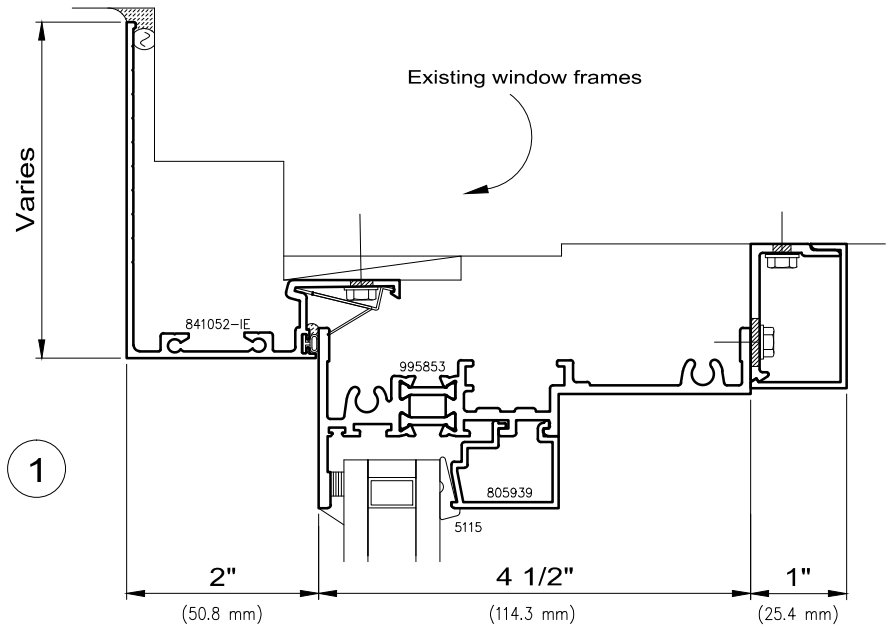
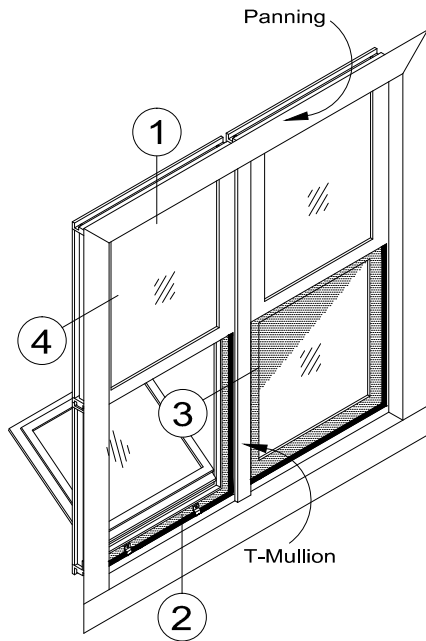

4250i INvent simulated double hung windows in multiple bays must be used in conjunction with T-mullions or H-mullions. Side stacking jambs not available.



**WAUSAU**

WINDOW AND WALL  
SYSTEMS

Simulated Double Hung  
Panning and T-Mullions

Architectural Windows

2250i/3250i/4250i INvent™ Series

Non-stocked items shown – Minimum order quantity may apply

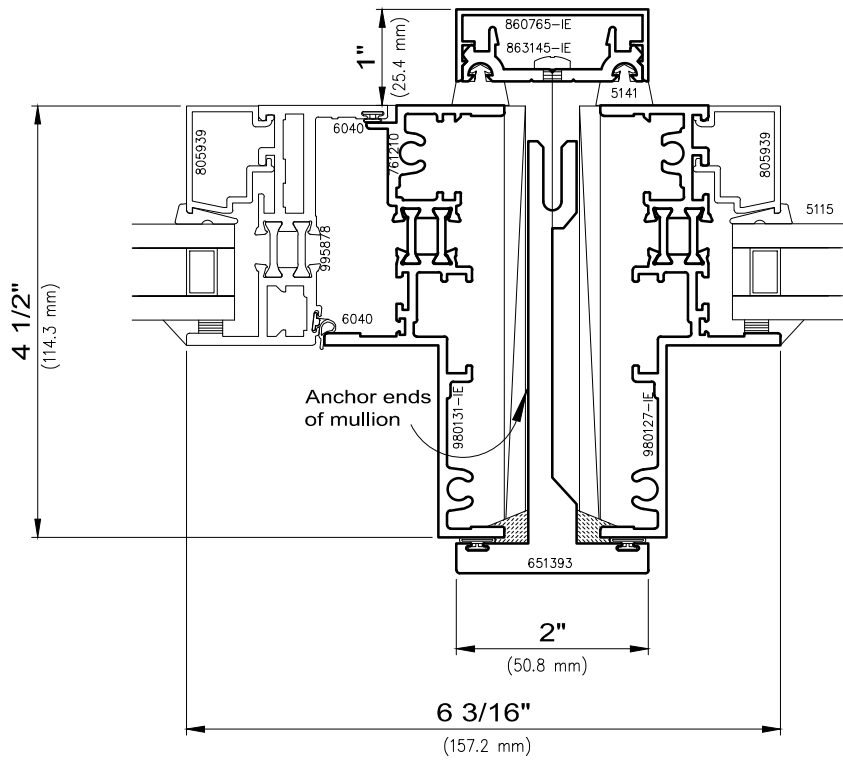

4250i INvent simulated double hung windows in multiple bays must be used in conjunction with T-mullions or H-mullions. Side stacking jambs not available.

3

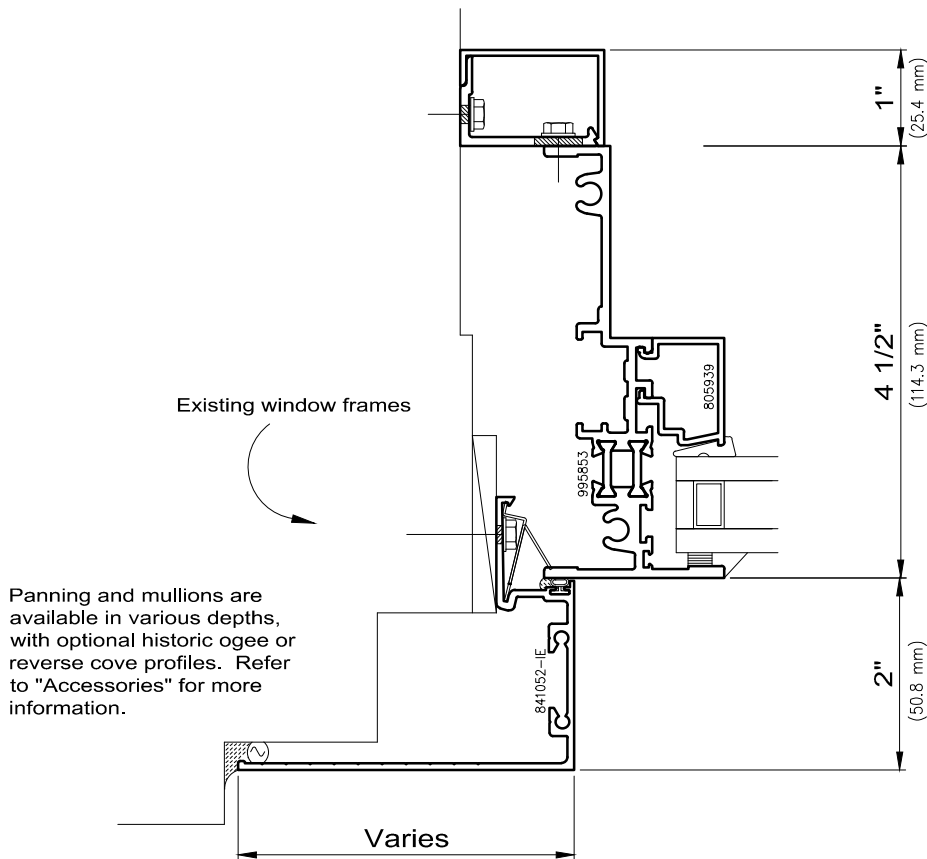

4



**WAUSAU**

WINDOW AND WALL  
SYSTEMS

Simulated Double Hung  
Starters and H-Mullions

Architectural Windows

2250i/3250i/4250i INvent™ Series

Head, jamb and sill starters are available in a number of face widths and water head heights. Please refer to "Series Accessories" for more information.

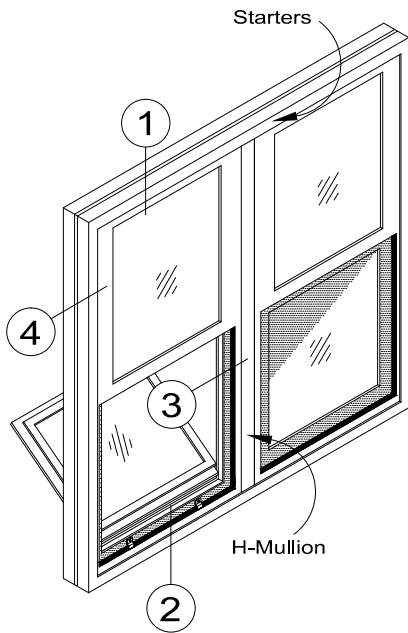

4250i INvent simulated double hung windows in multiple bays must be used in conjunction with T-mullions or H-mullions. Side stacking jambs not available.

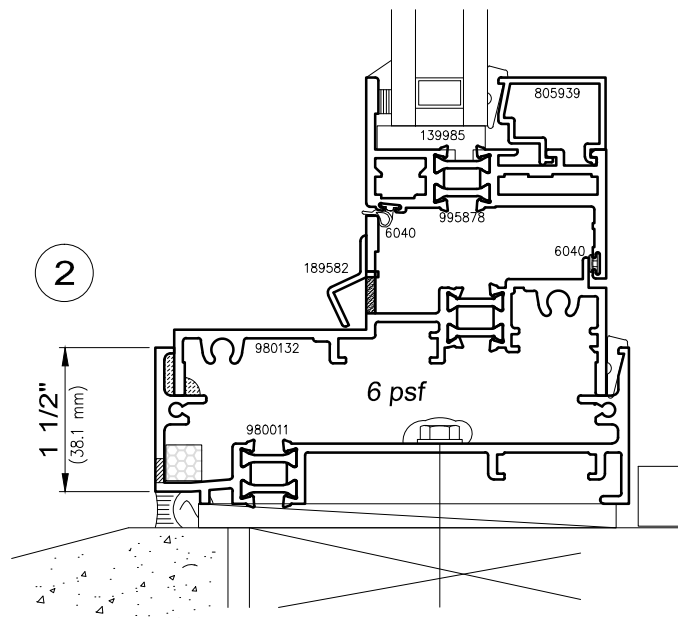
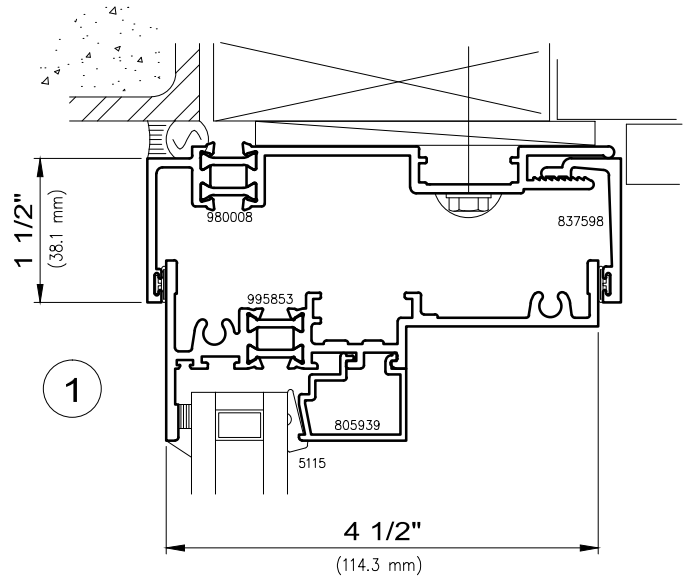



**WAUSAU**

WINDOW AND WALL  
SYSTEMS

Simulated Double Hung  
Starters and H-Mullions

Architectural Windows

2250i/3250i/4250i INvent™ Series

Non-stocked items shown - Minimum order quantity may apply

4250i INvent simulated double hung windows in multiple bays must be used in conjunction with T-mullions or H-mullions. Side stacking jambs not available.

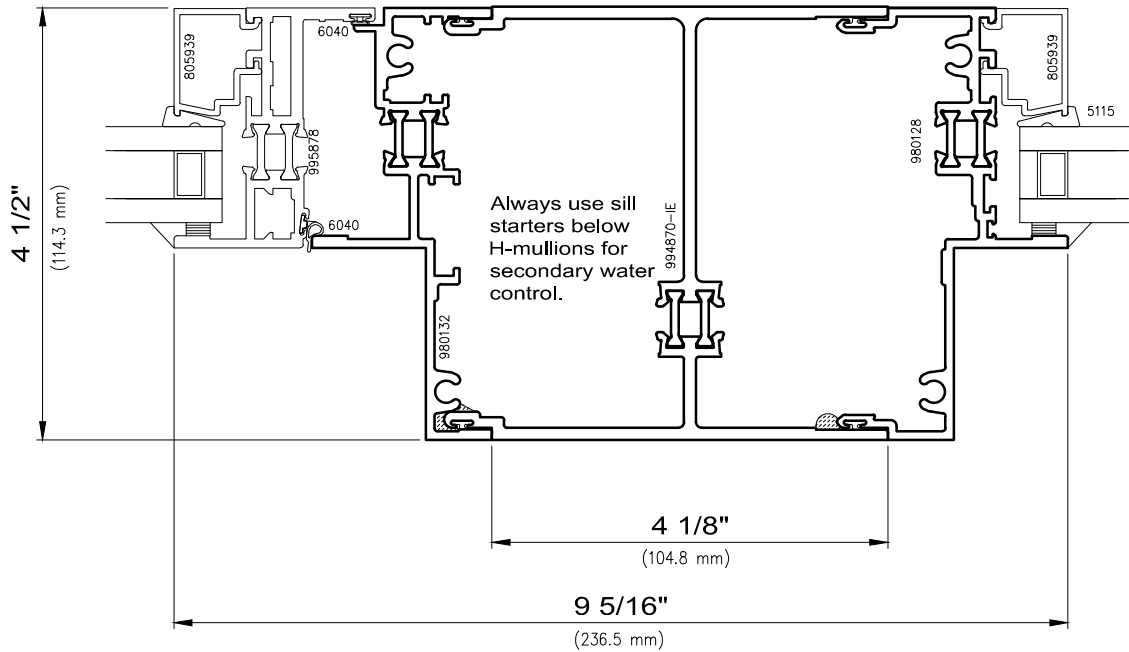

3

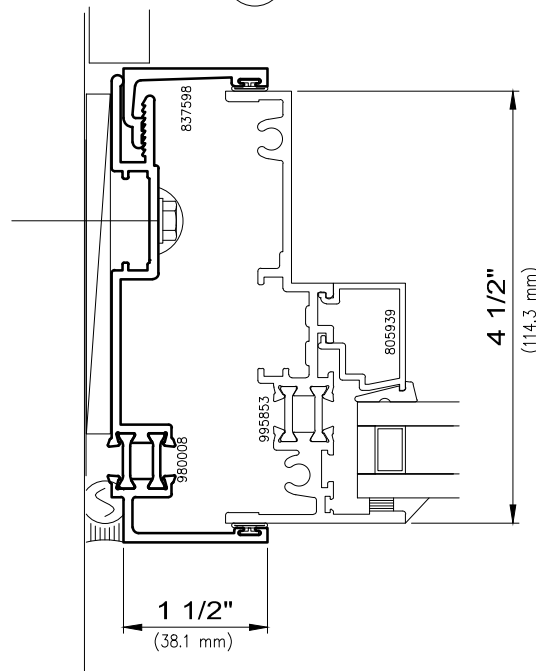

4

Head, jamb and sill starters are available in a number of face widths and water head heights. Please refer to "Series Accessories" for more information.



Architectural Windows

2250i/3250i/4250i INvent™ Series

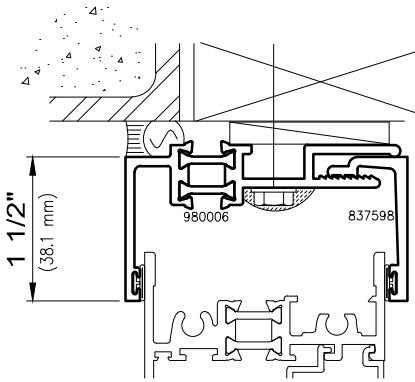

2250i Head & Jamb Starter

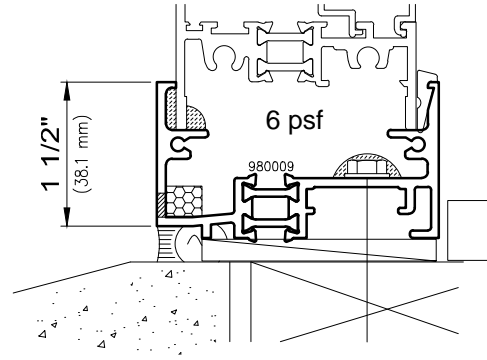

2250i Sill Starter

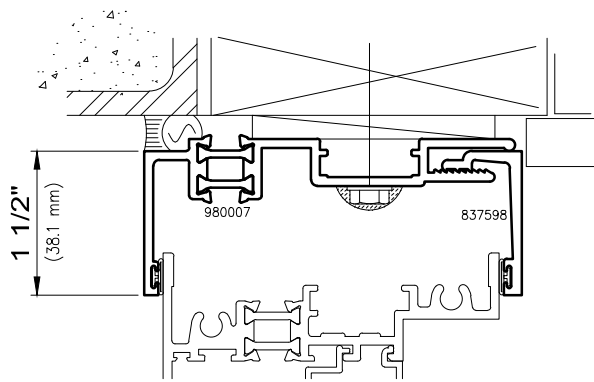

3250i Head & Jamb Starter

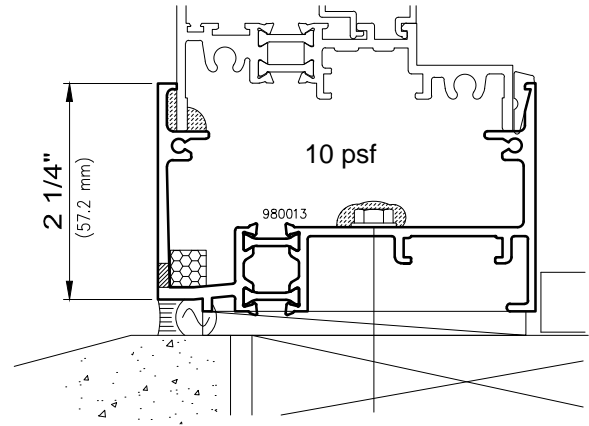

3250i Sill Starter

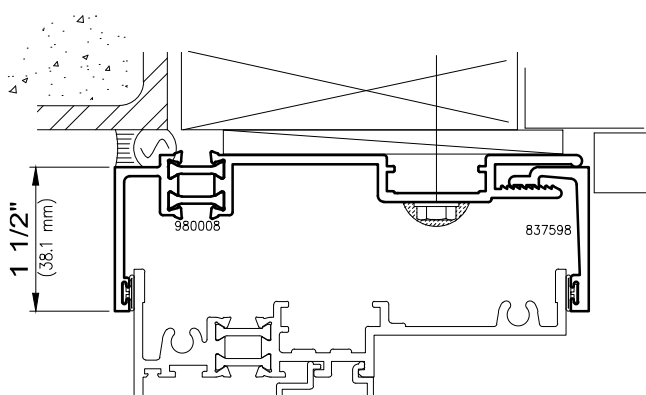

4250i Head & Jamb Starter

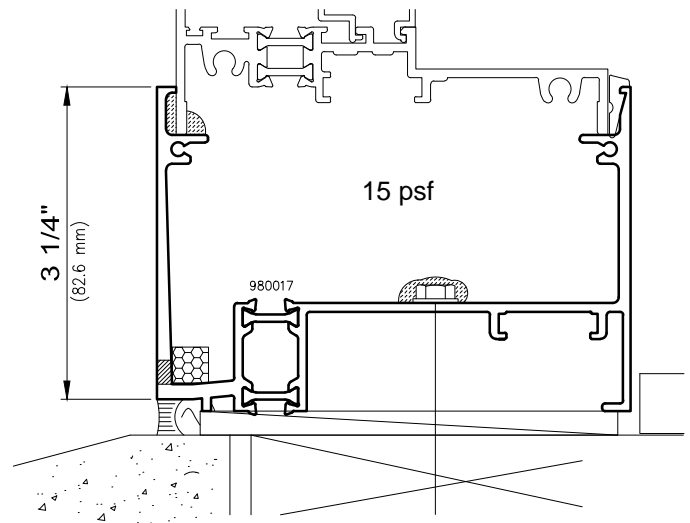

4250i Sill Starter

Value in psf Indicates Approximate Water Head Performance  
Other Sill Starters Available For Higher Water Test Pressures





**WAUSAU**

WINDOW AND WALL  
SYSTEMS

Accessories  
Anchors

Architectural Windows

2250i/3250i/4250i INvent™ Series

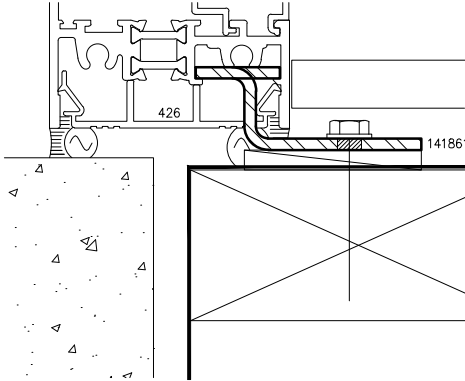

2250i Slide-In Anchor  
1/8" (nom.) Formed Steel

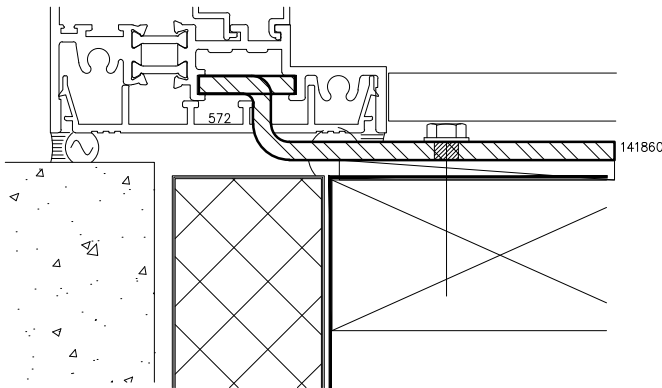

3250i Heavy Duty Slide-In Anchor  
3/16" (nom.) Formed Steel

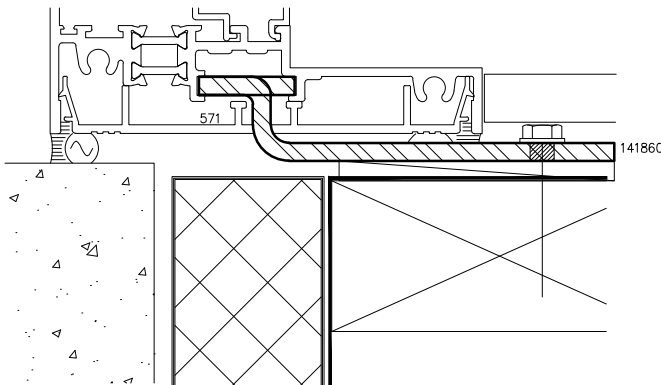

4250i Heavy Duty Slide-In Anchor  
3/16" (nom.) Formed Steel



**WAUSAU**

WINDOW AND WALL  
SYSTEMS

Accessories  
Frame Extenders and Caulk Backers

Architectural Windows

2250i/3250i/4250i INvent™ Series

Non-stocked items shown - Minimum order quantity may apply

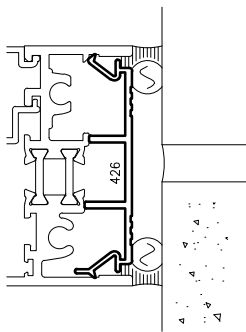
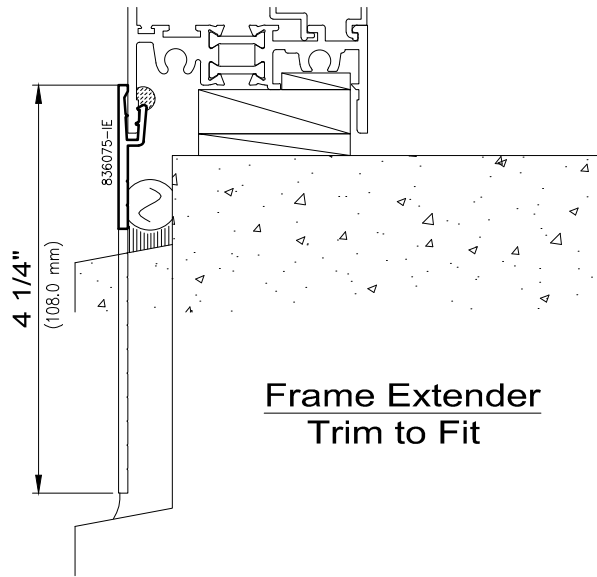

2250i

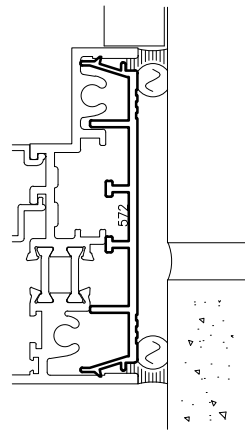

3250i

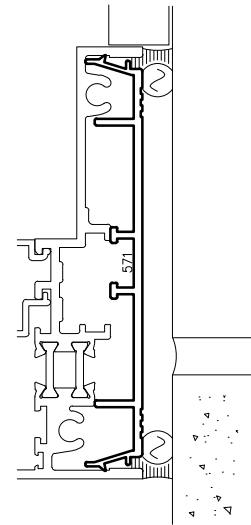

4250i

PVC Caulk Backers



**WAUSAU**

WINDOW AND WALL  
SYSTEMS

Accessories  
Optional Nailing Fin Anchor

Architectural Windows

2250i/3250i/4250i INvent™ Series

Non-stocked items shown – Minimum order quantity may apply

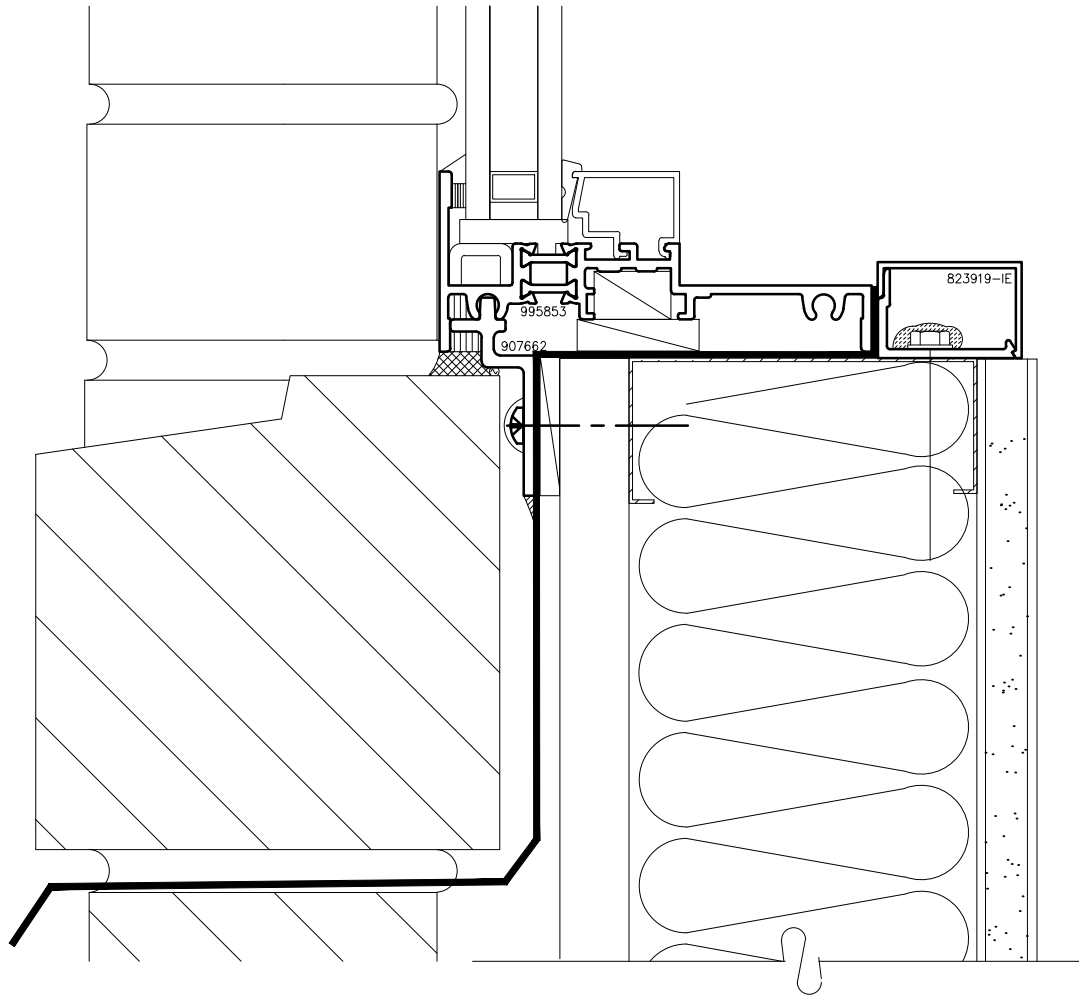

**Nailing Fin  
Exterior Anchor**



**WAUSAU**

WINDOW AND WALL  
SYSTEMS

Exploded Starter System Installation

Architectural Windows

2250i/3250i/4250i INvent™ Series

Key:

- 1 Extruded Aluminum Head And Jamb Starter With Polyamide Thermal Barrier
- 2 Extruded Aluminum Sill Starter With Polyamide Thermal Barrier
- 3 Drive-On Starter Strip
- 4 Structural Attachment May Vary Per Conditions - Field Seal All Fastener Heads
- 5 Erector Installed Full-Bearing Shims
- 6 Aluminum Splices With Bond Breaker Tape - Erector Set In Sealant and Exterior Applied Sealant Joint
- 7 Aluminum Splice - Erector Set In Sealant
- 8 Erector Installed And Tooled Expansion / Splice Joint
- 9 Foam Baffle Weep Back-Up
- 10 Perimeter Sealant Joint, Specified Sealant And Backer Rod
- 11 Insulation
- 12 Stone Lintel
- 13 Brick
- 14 Interior Concrete Block

Note: Installation Conditions Vary...

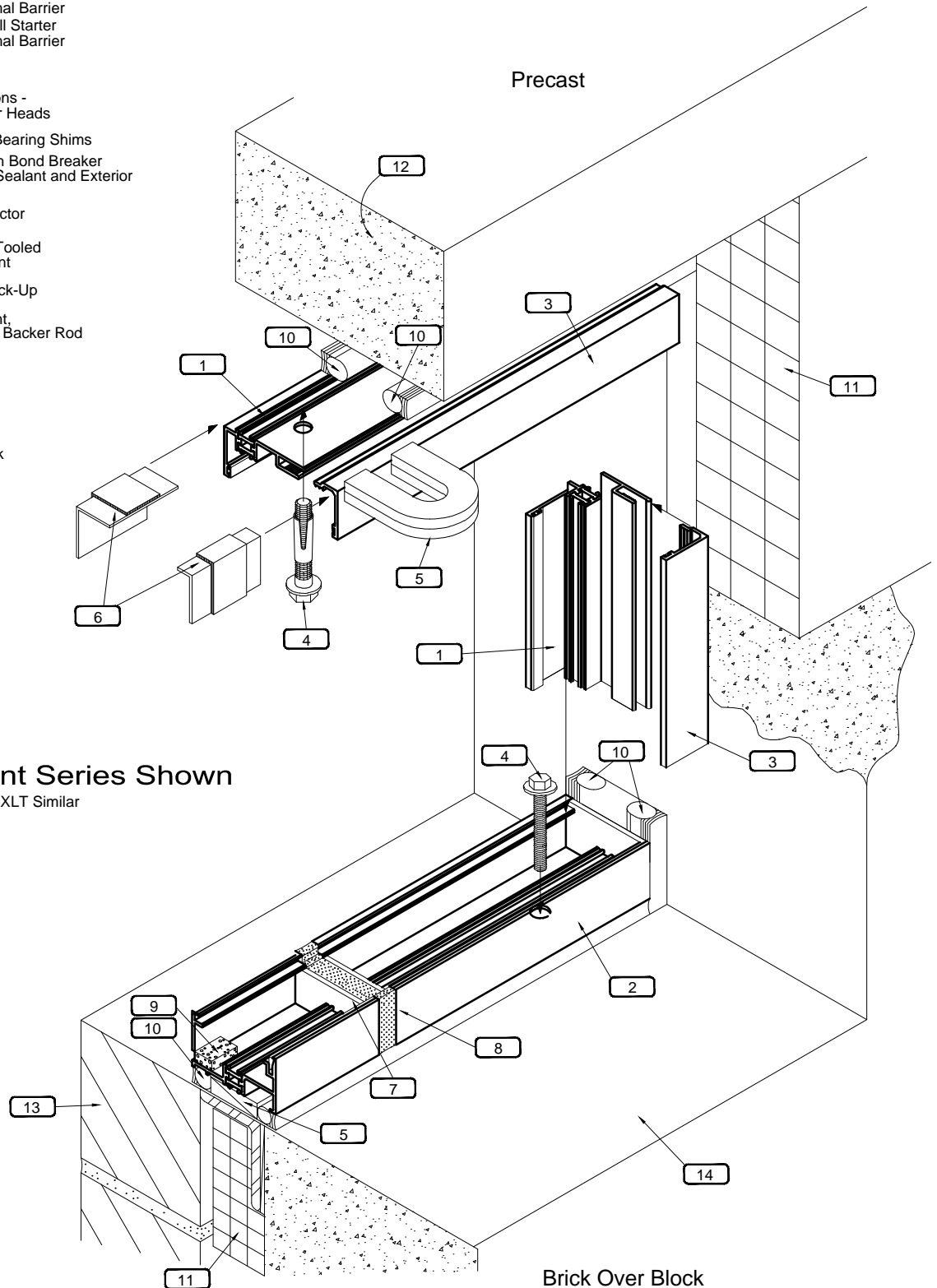

2250i INvent Series Shown  
-XLT Similar



# WAUSAU

WINDOW AND WALL  
SYSTEMS

## Exploded Window Installation

### Architectural Windows

### 2250i/3250i/4250i INvent™ Series

#### Frames

- 1 Extruded Frame Extender (When Required)
- 2 PVC Caulk Backer
- 3 Specified Rod And Perimeter Sealant
- 4 Erector Dead Load Shim

#### Anchorage (Using Slide-In Anchors)

- 5 Stainless Steel Fasteners Suitable For Substrate Material
- 6 Steel Slide-In Anchor With Fasteners (When Required At 3 1/2" And 4 1/2" Depth Systems)

#### Perimeter

- 7 Brick
- 8 Flashing
- 9 Insulation
- 10 Always Maintain Vapor Barrier Between Frame And Adjacent Walls
- 11 General Contractor Provide Blocking To Secure Attachment Into Steel Studs
- 12 Erector Installed Full-Bearing Shim

### 2250i INvent Series Shown

-XLT Similar

